

## P5 & P7 POWERED SLIDES

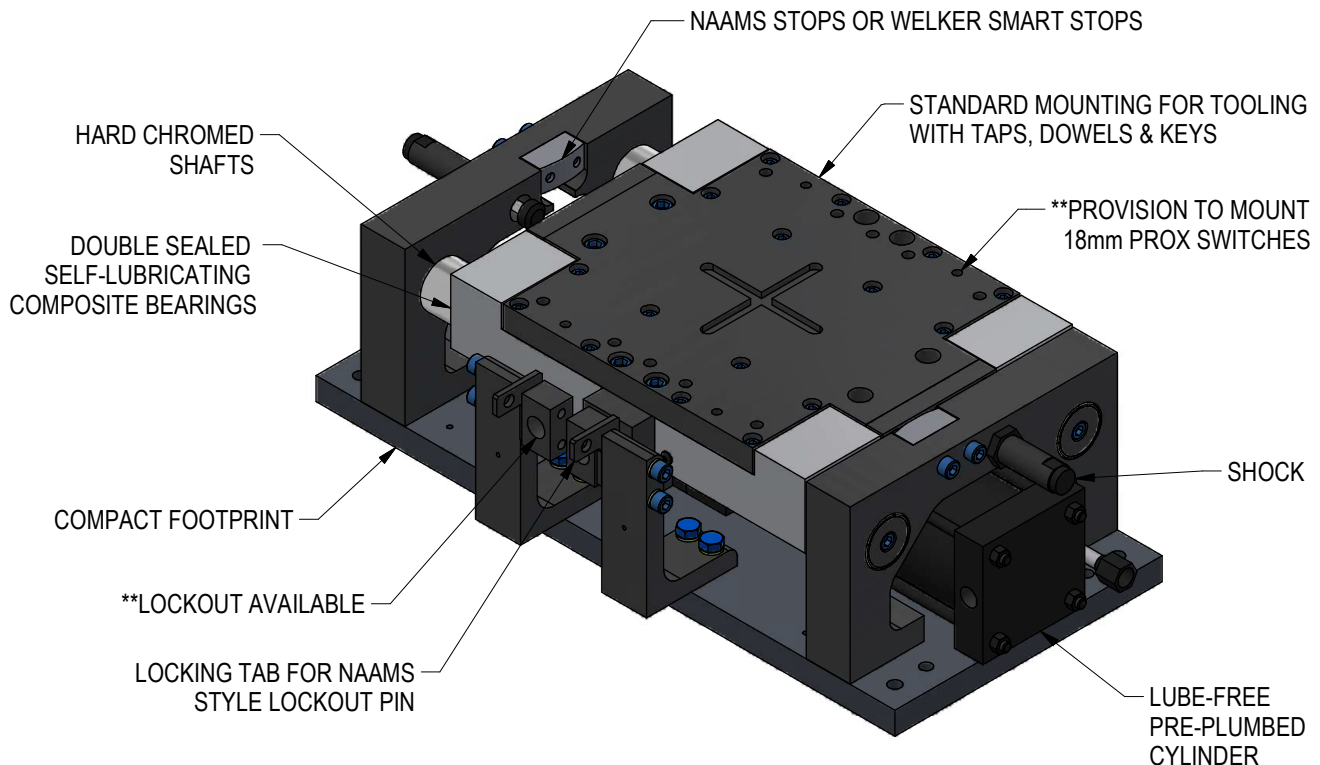

**WELKER POWERED SLIDES** provide all the desired features features that engineers & designers demand. The compact, yet robust powered slides have been designed to provide symmetry and flexibility of installation. P Series Slides are available in two sizes & capabilities. They can be mounted in any orientation and are designed to operate successfully in harsh environments. Pneumatic cylinders - non-locking, locking and duplex. Hydraulic and electric/servo actuators also available.

### APPLICATIONS:

*Weld Guns*

*Nut Runners*

\*\*The manual lockout brackets and proximity switch mounts are reversible and can be relocated in the field or called out in the part number. Up to 35mm of spacers are available for the NAAMS stops or Smart Stops on both ends of the slide. Spacers will also be added to manual lockout when this option is specified.

RELEASED 2/21/23

# ORDERING INFORMATION FOR NON-DUPLEX CYLINDER UNITS

NOTE: ALL BOXES MUST BE FILLED IN FOR A COMPLETE PART NUMBER

DUPLEX CYLINDER  
ORDER INFO  
SHEET 3 >>>

	0	0	0																
--	---	---	---	--	--	--	--	--	--	--	--	--	--	--	--	--	--	--	--

**Series**

- P5** 100mm Bore, 50mm Shaft
- P7** 150mm Bore, 75mm Shaft

**\*Total Stroke**

**050-500** Total Stroke  
(Standard Strokes in 25mm Increments)

**Cylinder Options (Pneumatic)**

- 01** Double Acting (NPT Ports)
- 03** Double Acting (G Ports)
- 04** Double Acting with Rod Lock (NPT Ports)
- 06** Double Acting with Rod Lock (G Ports)

**Lockout & Switch Mounting Options**

- |   |   |  |
|---|---|--|
| <b>X</b> NONE                                   | } | <i>Available with 0 or P<br/>from <b>Options</b></i> |
| <b>A</b> Lockout only - LH Side                 |   |  |
| <b>B</b> Lockout only - RH Side                 |   |  |
| <b>C</b> Switch Mount only LH Side              | } | <i>Available with X or C<br/>from <b>Options</b></i> |
| <b>E</b> Switch Mount LH Side & Lockout RH Side |   |  |
| <b>F</b> Switch Mount only - RH Side            |   |  |
| <b>G</b> Switch Mount RH Side & Lockout LH Side |   |  |

**\*\*Retract Shim: Whole mm**

**\*\*Retract Shim: Quarter mm**

**\*\*Extend Shim: Whole mm**

**\*\*Extend Shim: Quarter mm**

**Options**

- 0** No Switch Mount
- P** Welker Smart Stop
- X** 18mm Barrel Prox Mount
- C** Cube Switch Mount

**Rod Lock Cylinder Application Note:**

Cylinder Rod Locks are intended to function as static holding devices and are suitable for infrequent dynamic braking (emergency stops). The Rod Lock is intended to be energized at each end of stroke, however, avoid repeated forced motion during engagement or disengagement.

**\*Stroke Note:** Units are built to standard total strokes from 50mm to 500mm in 25mm increments.

Total strokes for Duplex are 1st stroke plus 2nd stroke. If necessary, stops can be shimmed back to achieve the required travel. Non-standard strokes are available by special order and will increase lead time and spare part availability.

**\*\*Shim Note:** When ordering the shim option, units will have shim packs/grind spacers added to the NAAMS stops on both ends and it will shorten the total working stroke.

SHIM CHART									
WHOLE MILLIMETER CODES								QUARTER MM CODES	
THK (mm)	CODE	THK (mm)	CODE	THK (mm)	CODE	THK (mm)	CODE	.25 THK (mm)	CODE
0	0	8	8	16	G	24	R	0.00	0
1	1	9	9	17	H	25	S	0.25	A
2	2	10	A	18	J	26	T	0.50	B
3	3	11	B	19	K	27	U	0.75	C
4	4	12	C	20	L	28	V		
5	5	13	D	21	M	29	W		
6	6	14	E	22	N	30	X		
7	7	15	F	23	P	35	Y		

Manual lockouts both ends, prox switch mounts, and duplex cylinders are available on all models.

**Ordering example:** For a "P5" slide with 150mm stroke (150mm total stroke), double acting air cylinder, lockouts & barrel prox switches on LH side, no additional shims, order as:  
**P5000015001D0000X**

(DO NOT SCALE DRAWING)



ENGINEERED PRODUCTS

(800) 229-0890 www.welkerproducts.com

# ORDERING INFORMATION FOR DUPLEX CYLINDER UNITS

NOTE: ALL BOXES MUST BE FILLED IN FOR A COMPLETE PART NUMBER

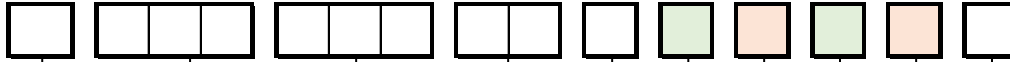

**Series**

- P5** 100mm Bore, 50mm Shaft
- P7** 150mm Bore, 75mm Shaft

**1st Stroke of Duplex**

- 000-495** 1st Stroke of Duplex

**\*2nd Stroke of Duplex**

- 050-500** 2nd Stroke of Duplex  
(Standard Strokes in 25mm Increments)

**Cylinder Options (Pneumatic)**

- 07** Duplex (NPT Ports)
- 09** Duplex (G Ports)
- 10** Duplex with Rod Lock (NPT Ports)
- 12** Duplex with Rod Lock (G Ports)

**Lockout & Switch Mounting Options**

- C** Switch Mount only - LH Side
- D** Switch Mount & Lockout - LH Side (Not P5)
- E** Switch Mount LH Side & Lockout RH Side
- F** Switch Mount only - RH Side
- G** Switch Mount RH Side & Lockout LH Side
- H** Switch Mount & Lockout - RH Side (Not P5)

**\*\*Retract Shim: Whole mm**

**\*\*Retract Shim: Quarter mm**

**\*\*Extend Shim: Whole mm**

**\*\*Extend Shim: Quarter mm**

**Options**

- B** 18mm Barrel Switch Mount & Smart Stop
- D** Cube Switch Mount & Smart Stop

**Rod Lock Cylinder Application Note:**

Cylinder Rod Locks are intended to function as static holding devices and are suitable for infrequent dynamic braking (emergency stops). The Rod Lock is intended to be energized at each end of stroke, however, avoid repeated forced motion during engagement or disengagement.

**\*Stroke Note:** Units are built to standard total strokes from 50mm to 500mm in 25mm increments.

Total strokes for Duplex are 1st stroke plus 2nd stroke. If necessary, stops can be shimmed back to achieve the required travel. Non-standard strokes are available by special order and will increase lead time and spare part availability.

**\*\*Shim Note:** When ordering the shim option, units will have shim packs/grind spacers added to the NAAMS stops on both ends and it will shorten the total working stroke.

SHIM CHART									
WHOLE MILLIMETER CODES								QUARTER MM CODES	
THK (mm)	CODE	THK (mm)	CODE	THK (mm)	CODE	THK (mm)	CODE	.25 THK (mm)	CODE
0	<b>0</b>	8	<b>8</b>	16	<b>G</b>	24	<b>R</b>	0.00	<b>0</b>
1	<b>1</b>	9	<b>9</b>	17	<b>H</b>	25	<b>S</b>	0.25	<b>A</b>
2	<b>2</b>	10	<b>A</b>	18	<b>J</b>	26	<b>T</b>	0.50	<b>B</b>
3	<b>3</b>	11	<b>B</b>	19	<b>K</b>	27	<b>U</b>	0.75	<b>C</b>
4	<b>4</b>	12	<b>C</b>	20	<b>L</b>	28	<b>V</b>		
5	<b>5</b>	13	<b>D</b>	21	<b>M</b>	29	<b>W</b>		
6	<b>6</b>	14	<b>E</b>	22	<b>N</b>	30	<b>X</b>		
7	<b>7</b>	15	<b>F</b>	23	<b>P</b>	35	<b>Y</b>		

Manual lockouts both ends, prox switch mounts, and duplex cylinders are available on all models.

**Ordering example:** For a "P5" slide with 45mm first stroke, 225mm second stroke (270mm total stroke), duplex air cylinder, no lockout & cube switch mount on LH side, 2mm retract shim, 0.75mm extend shim, order as: **P504522507C200CD**

(DO NOT SCALE DRAWING)



ENGINEERED PRODUCTS

(800) 229-0890 www.welkerproducts.com

# GENERAL DIMENSIONS

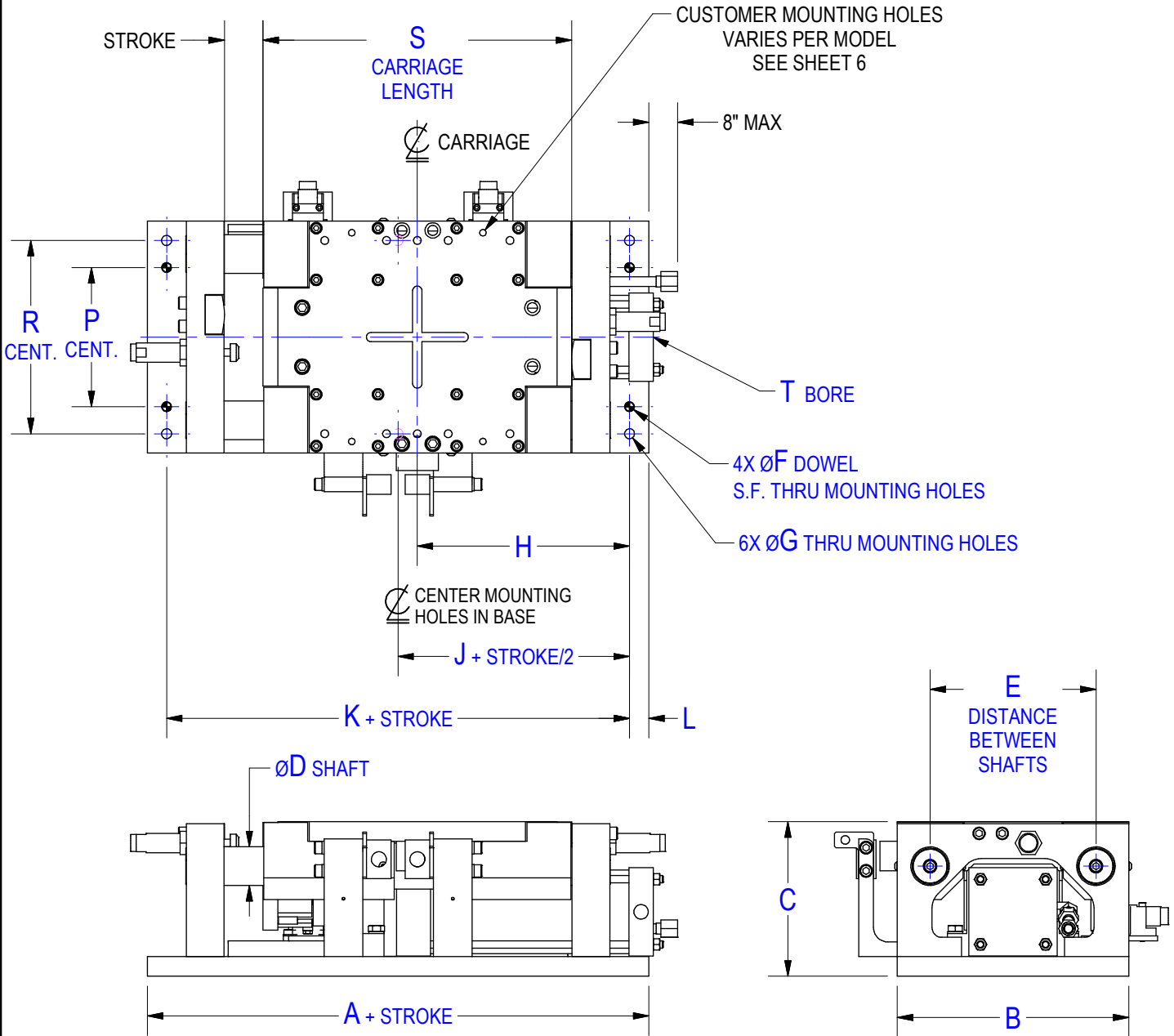

Series	A	B	C	$\varnothing D$	E	$\varnothing F$	$\varnothing G$	H	J	K
<b>P5</b>	600	300	200	50	215	12	13	275	275	550.00
<b>P7</b>	775	500	260	75	365	16	17	368	368	736.00

	L	P	R	S	T	WEIGHT
<b>P5</b>	25	180.00	250.00	400	100mm	285 lbs (1268 N) + 10 lbs (44 N) / 25mm
<b>P7</b>	19.5	370.00	470.00	550	150mm	865 lbs (3848 N) + 11.3 lbs (50 N) / 25mm



(DO NOT SCALE DRAWING)



ENGINEERED PRODUCTS

(800) 229-0890 www.welkerproducts.com

# CYLINDER OPTIONS

SERIES P5, P7

**P5** 0 0 0 0 5 0 0 1 E 0 0 0 0 X

## Cylinder Options (Pneumatic)

CYLINDER OPTION	MIN CYL LENGTH	*CYLINDER LENGTH	CYL PORTS	BRAKE PORTS	CYL TYPE
<b>01</b> Double Acting (NPT Ports)	A	B + STK	C NPT	N/A	NON-LOCK
<b>03</b> Double Acting (G Ports)	A	B + STK	E G	N/A	NON-LOCK
<b>04</b> Double Acting with Rod Lock (NPT Ports)	F	G + STK	C NPT	R NPT	LOCK
<b>06</b> Double Acting with Rod Lock (G Ports)	F	G + STK	E G	T G	LOCK
<b>07</b> Duplex (NPT Ports)	N/A	H + STK + **TOTAL STROKE + 1ST STROKE	C NPT	N/A	DUPLEX
<b>09</b> Duplex ("G" Ports)	N/A	H + STK + **TOTAL STROKE + 1ST STROKE	E G	N/A	DUPLEX
<b>10</b> Duplex with Rod Lock (NPT Ports)	N/A	J + STK + **TOTAL STROKE + 1ST STROKE	C NPT	R NPT	LOCKING DUPLEX
<b>12</b> Duplex with Rod Lock (G Ports)	N/A	J + STK + **TOTAL STROKE + 1ST STROKE	E G	T G	LOCKING DUPLEX

\*CYLINDER LENGTH MAY INCLUDE OVERSTROKE, SPACERS OR OTHER VARIABLES. FOR MOUNTINGS & LENGTHS OF NON-STANDARD CYLINDERS, CONSULT WELKER.

\*\*TOTAL STROKE = 1ST STROKE + 2ND STROKE. 1ST STROKE STARTS FROM CARRIAGE IN RETRACTED POSITION AS SHOWN.

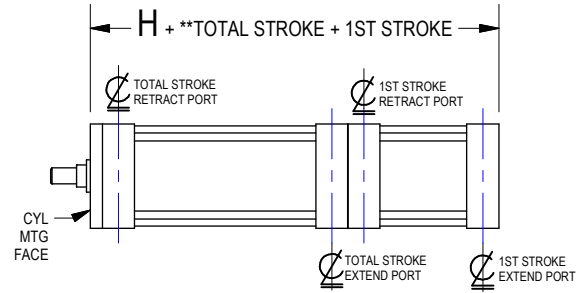

## CYLINDER OPTIONS 07, 09

(SEE NOTE)

**NOTE:** ALL INACCESSIBLE PORTS WILL BE PRE-PLUMBED BY WELKER WITH FITTINGS THAT WILL BE ACCESSIBLE OUTSIDE THE END PLATE AND WITHIN 8" FROM THE BASE PLATE. WHEN "G" PORT OPTION IS ORDERED, METRIC TUBING & FITTINGS WILL BE SUPPLIED WHEN NECESSARY.

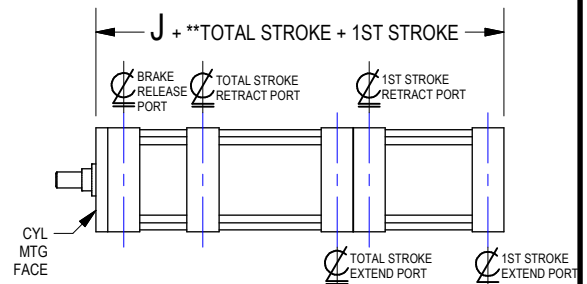

## CYLINDER OPTIONS 10, 12

(SEE NOTE)

**L** FEMALE THREAD 37° FLARE FITTING

FOR **M** O.D. TUBING FROM CYLINDER ROD END. LOCATION WILL VARY PER CYLINDER. WHEN "G" PORT OPTION IS ORDERED,

**M** O.D. METRIC TUBING WILL BE SUPPLIED LESS FITTINGS & WILL BE ACCESSIBLE.

**N** FEMALE THREAD 37° FLARE FITTING

FROM BRAKE PORT FOR **P** O.D. TUBING **FOR LOCKING CYLINDER OPTION ONLY.** LOCATION WILL VARY PER CYLINDER

WHEN "G" PORT OPTION IS ORDERED, **P** O.D. METRIC TUBING WILL BE SUPPLIED LESS FITTINGS & WILL BE ACCESSIBLE.

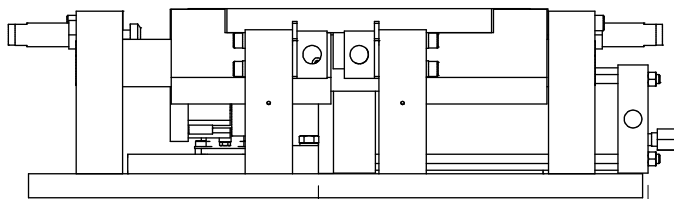
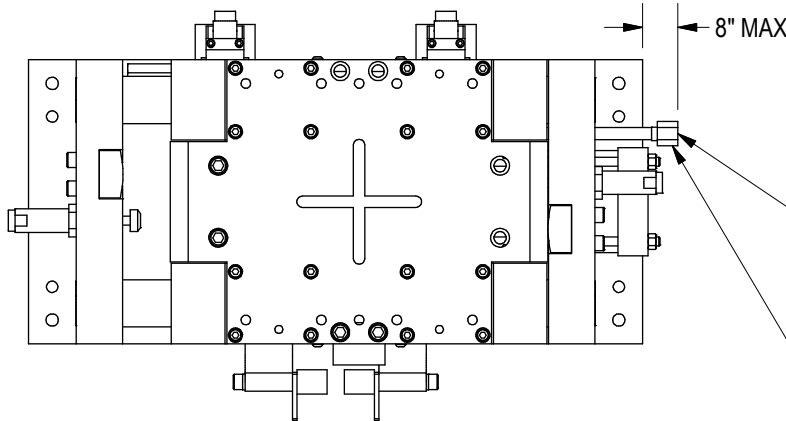

## CYLINDER OPTIONS 01-06

K TO CYL MNT FACE

GREATER OF CYL MNT LENGTH OR CYL LENGTH ~ SEE CHART

	A	B	C	D	E	F	G	H	J	K	L	M	N	P	R	S	T
<b>P5</b>	350	150	1/2"	#10	1/2	365	265	265	385	343	3/4-16" or 3/4G	1/2" or 12mm	7/16" or 7/16G	1/4" or 6mm	1/4"	#4	1/4
<b>P7</b>	520	200	3/4"	#12	1/2	520	320	350	475	514.8	1 1/16"-12 or 1 1/16"G	3/4" or 20mm	7/16" or 7/16G	1/4" or 6mm	1/4"	#4	1/4

### Rod Lock Cylinder Application Note:

Cylinder Rod Locks are intended to function as static holding devices and are suitable for infrequent dynamic braking (emergency stops). The Rod Lock is intended to be energized at each end of stroke, however, avoid repeated forced motion during engagement or disengagement.

(DO NOT SCALE DRAWING)



ENGINEERED PRODUCTS

(800) 229-0890 www.welkerproducts.com

# CARRIAGE SHEET

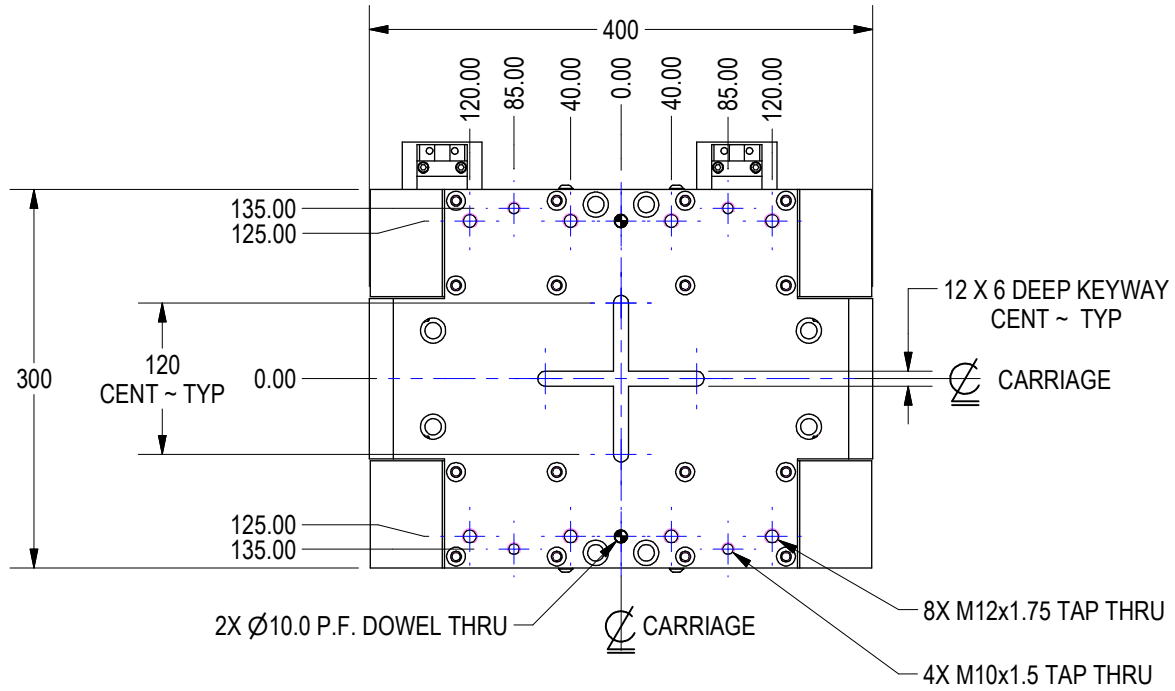

## P5 CARRIAGE

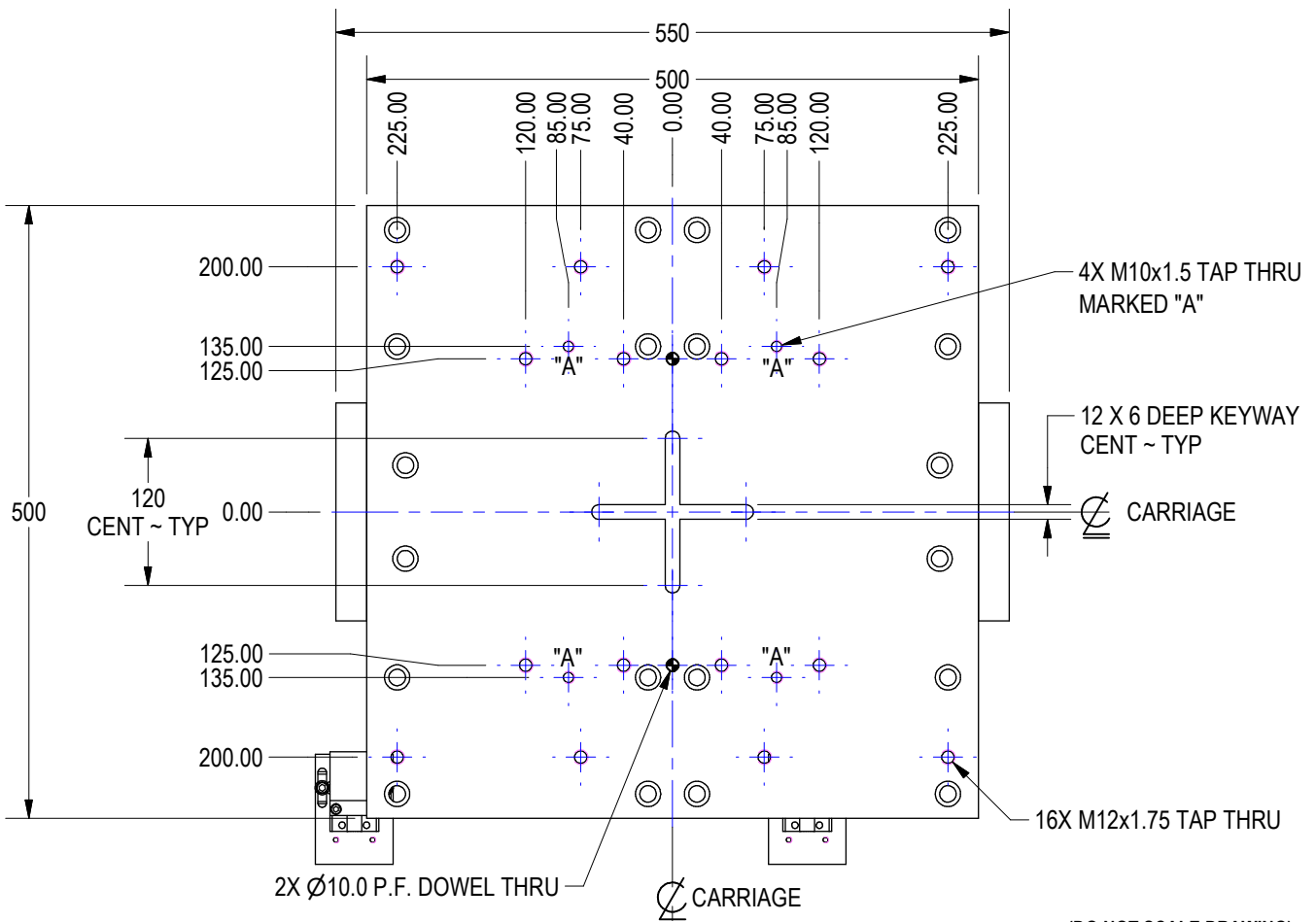

## P7 CARRIAGE

(DO NOT SCALE DRAWING)



ENGINEERED PRODUCTS

(800) 229-0890 www.welkerproducts.com

# P5 SERIES LOCKOUTS & SWITCHES

## NON-DUPLEX CYLINDERS:

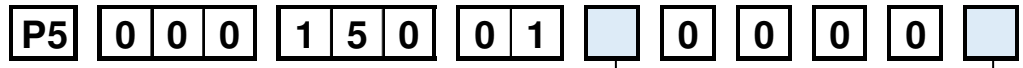

### Lockout & Switch Mounting Options

- X** None
- A** Lockout only - LH Side
- B** Lockout only - RH Side
- C** Switch Mount only - LH Side
- E** Switch Mount LH Side & Lockout RH Side
- F** Switch Mount only - RH Side
- G** Switch Mount RH Side & Lockout LH Side

### Options

- 0** No Switch Mount
- P** Welker Smart Stop
- X** 18mm Barrel Switch Mount
- C** Cube Switch Mount

## DUPLEX CYLINDERS:

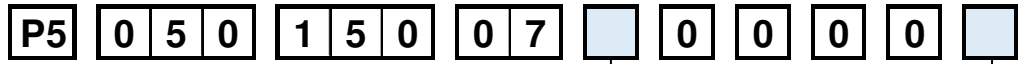

### Lockout & Switch Mounting Options

- C** Switch Mount only - LH Side
- E** Switch Mount LH Side & Lockout RH Side
- F** Switch Mount only - RH Side
- G** Switch Mount RH Side & Lockout LH Side

### Options

- B** 18mm Barrel Switch Mount & Smart Stop
- D** Cube Switch Mount & Smart Stop

LOCKING TAB FOR NAAMS STYLE LOCKOUT PIN INCLUDED WITH LOCKOUT OPTIONS A, B, E & G

LOCKOUT TAB DETAIL SHOWN IN LOCKED POSITION WITH TRU-LOK PIN AND LOCK

LOCKOUT PIN SOLD SEPARATELY SEE SHEET 8

LOCK (NOT INCLUDED)

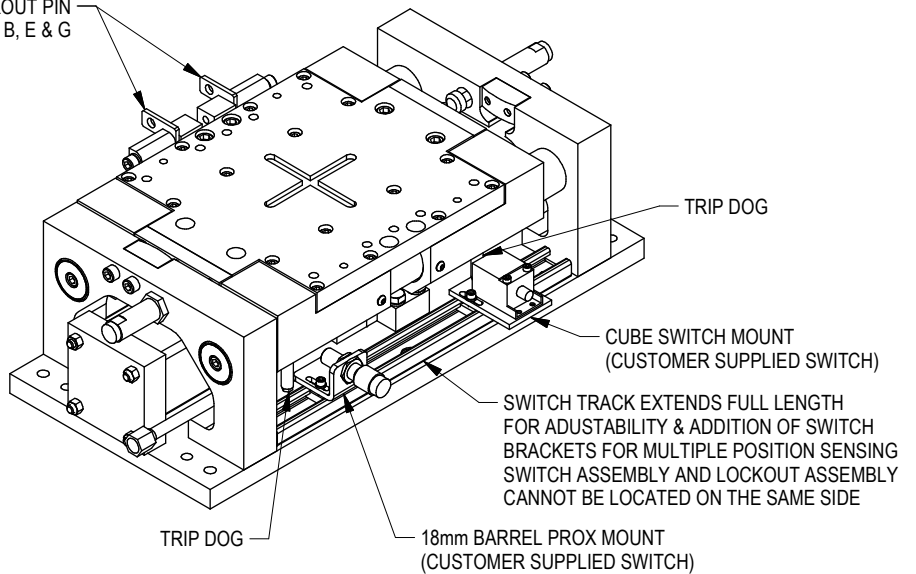

EXTEND STOP OR SMART STOP ACCEPTS UP TO 35mm OF SHIMS (SEE NOTE 1)

RETRACT STOP OR SMART STOP ACCEPTS UP TO 35mm OF SHIMS (SEE NOTE 1)

**NOTE 1:**  
THE ADDITION OF ANY SHIMS ON EITHER END WILL SHORTEN THE WORKING STROKE BY THE TOTAL AMOUNT OF ALL THE SHIMS ADDED

LOCKING TAB FOR NAAMS STYLE LOCKOUT PIN

LOCKOUT BLOCKS MUST BE SHIMMED THE SAME AS THE CORRESPONDING RETRACT / EXTEND STOP

LOCKOUT PIN/RECEIVER SOLD SEPARATELY AS PART #P5-PIN-KIT (KIT INCLUDES 2)

**RH SIDE**

**LH SIDE**

(DO NOT SCALE DRAWING)



ENGINEERED PRODUCTS

(800) 229-0890 www.welkerproducts.com

# TRU-LOK-OUT ASSEMBLY

**NOT INCLUDED WITH SLIDE: ORDER SEPARATELY**

NOTE: TRU-LOK-OUT ASSEMBLY IS SHIPPED LOOSE. CUSTOMER TO LOCATE AND MOUNT

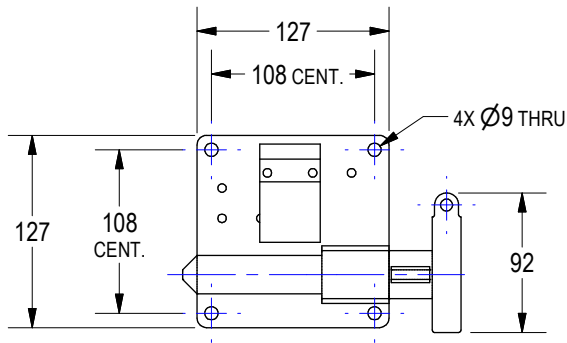
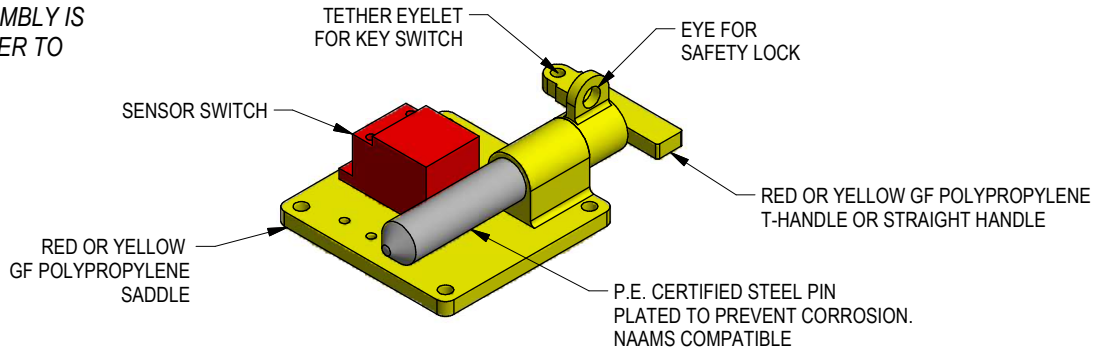

MATERIAL	4140 PHT, Rc 33
YIELD	95000
SHEAR YIELD	55100

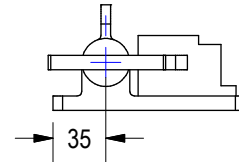
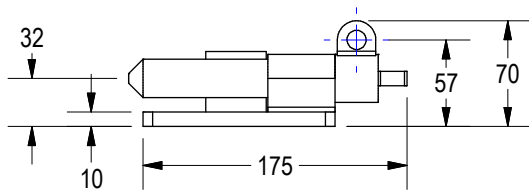

## ORDERING INFORMATION

NOTE: ALL BOXES MUST BE FILLED IN FOR A COMPLETE PART NUMBER

S	P	1	9		0	6	0			0	0		
---	---	---	---	--	---	---	---	--	--	---	---	--	--

**Saddle Color\***

- Y** Yellow
- R** Red

**Handle Style**

- T** T-Handle
- S** Straight

**Handle Color\***

- Y** Yellow
- R** Red

**Switch**

- 000** No Switch
- 200** Pepperl & Fuchs Cube Switch #NBB20-L3M-A2-C3-V1 [GM]
- 201** Turck Cube Switch #1627297 [FCA, Ford]

\* SPEC COLORS:

FCA: YELLOW SADDLE, YELLOW T-HANDLE  
 FORD: YELLOW SADDLE, YELLOW T-HANDLE  
 GM: YELLOW SADDLE, RED T-HANDLE

(DO NOT SCALE DRAWING)



ENGINEERED PRODUCTS

(800) 229-0890 www.welkerproducts.com



# P7 SERIES LOCKOUTS & SWITCHES

## NON-DUPLEX CYLINDERS:

**P7** **0 0 0** **1 5 0** **0 1**  **0 0 0 0**

### Lockout & Switch Mounting Options

- X** None
- A** Lockout only - LH Side
- B** Lockout only - RH Side
- C** Switch Mount only - LH Side
- E** Switch Mount LH Side & Lockout RH Side
- F** Switch Mount only - RH Side
- G** Switch Mount RH Side & Lockout LH Side

### Options

- 0** No Switch Mount
- P** Welker Smart Stop
- X** 18mm Barrel Switch Mount
- C** Cube Switch Mount

## DUPLEX CYLINDERS:

**P7** **0 5 0** **1 5 0** **0 7**  **0 0 0 0**

### Lockout & Switch Mounting Options

- C** Switch Mount only - LH Side
- D** Switch Mount & Lockout - LH Side
- E** Switch Mount LH Side & Lockout RH Side
- F** Switch Mount only - RH Side
- G** Switch Mount RH Side & Lockout LH Side
- H** Switch Mount & Lockout - RH Side

### Options

- B** 18mm Barrel Switch Mount & Smart Stop
- D** Cube Switch Mount & Smart Stop

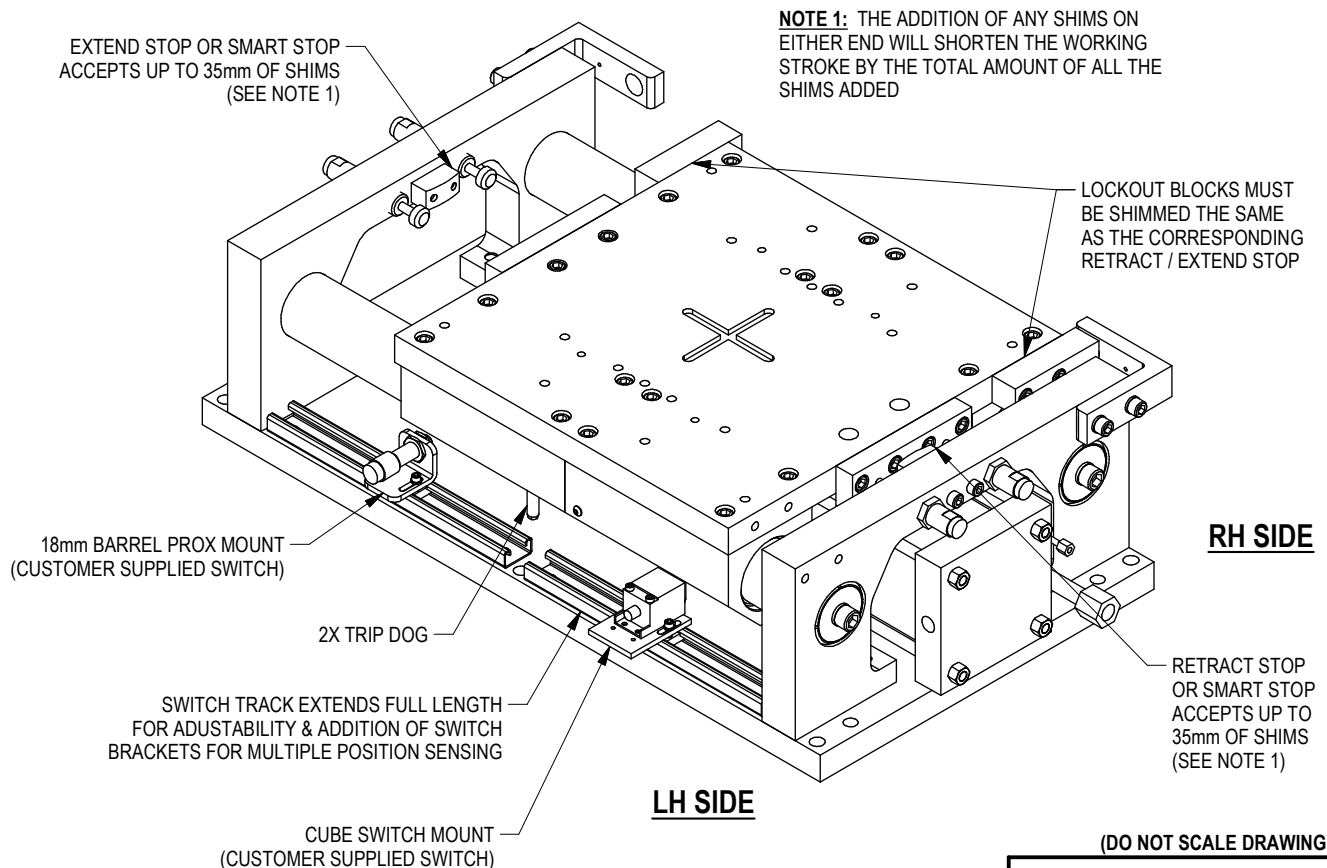

(DO NOT SCALE DRAWING)

**WELKER**

ENGINEERED PRODUCTS

(800) 229-0890 www.welkerproducts.com

# WELKER SMART STOP

**WELKER SMART STOP** does all stopping & sensing functions in one part.  
**SMART STOP** minimizes engineering, field set up and operator adjustment time.

**WELKER SMART STOP** eliminates:

- Need for separate mounts, brackets & flags.
- Need for switch adjustments when shimming.
- Improper adjustment of outboard switches.
- Outboard switch vibrating loose in bracket.
- Protecting outboard proxies from being stepped on or bent in tools.

MODEL NO:  
 ASC020-PD FOR CROWNED, DRILL & C'BORE FOR M10 SHCS + DC SWITCH  
 ASC021-PD FOR CROWNED, M10X1.5 TAP + DC SWITCH  
 ASC020-PD FOR FLAT, DRILL & C'BORE FOR M10 SHCS + DC SWITCH  
 ASC021-PD FOR FLAT, M10X1.5 TAP + DC SWITCH

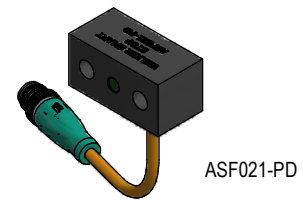
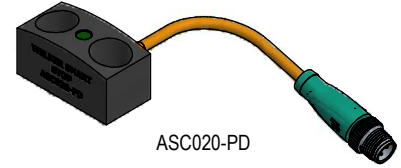
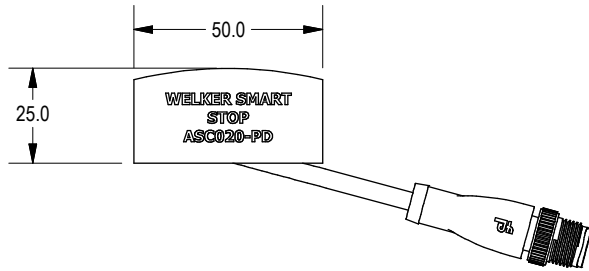

## General Specifications

Switching function	Normally Open (NO)
Output type	PNP
Rated operating distance, $s_n$	1.75mm
Output polarity	DC
Assured operating distance $s_a$	0 - 1.42 mm
Output type	3-wire

## Nominal Ratings

Operating voltage, $U_B$	5 - 30 V DC
Switching frequency, $f$	0 - 6000 Hz
Reverse polarity protection	Reverse polarity protected
Short-circuit protection	Pulsing
Voltage drop, $U_d$	$\leq 1.5$ V
Operating current, $I_L$	0 - 100 mA
Off-state current, $I_r$	0 - 0.2 mA
No-load supply current, $I_0$	$\leq 15$ mA

## Indicators/Operating Means

Operating voltage indicator	LED green
Switching state indicator	LED yellow

## Ambient Conditions

Ambient temperature	-40 - 85 °C (-40 - 185 °F)
Storage temperature	-40 - 85 °C (-40 - 185 °F)

## Mechanical Specifications

Connection type Connector plug	M12 x 1 , 4-pin
Cable length	255mm
Degree of protection	IP67
Cable material	Weld spatter resistant, robotic quality POC
Cable color	Orange

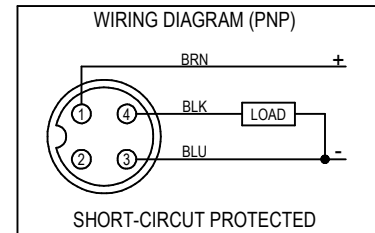

(DO NOT SCALE DRAWING)



ENGINEERED PRODUCTS

(800) 229-0890 www.welkerproducts.com

# P5 SLIDE ACCURACY

**POSITIONAL ACCURACY** specifies the allowable deviation between the nominal position of a reference point on the carriage (D1 as shown) to the actual position that is achieved.

**TRAVEL ACCURACY** specifies the allowable deviation along the plane of motion of a reference point on the carriage (D1 as shown) to the actual position *during movement* - in other words, the allowable side-to-side movement (in the direction of Y) and up-and-down movement (in the direction of Z) as the unit travels.

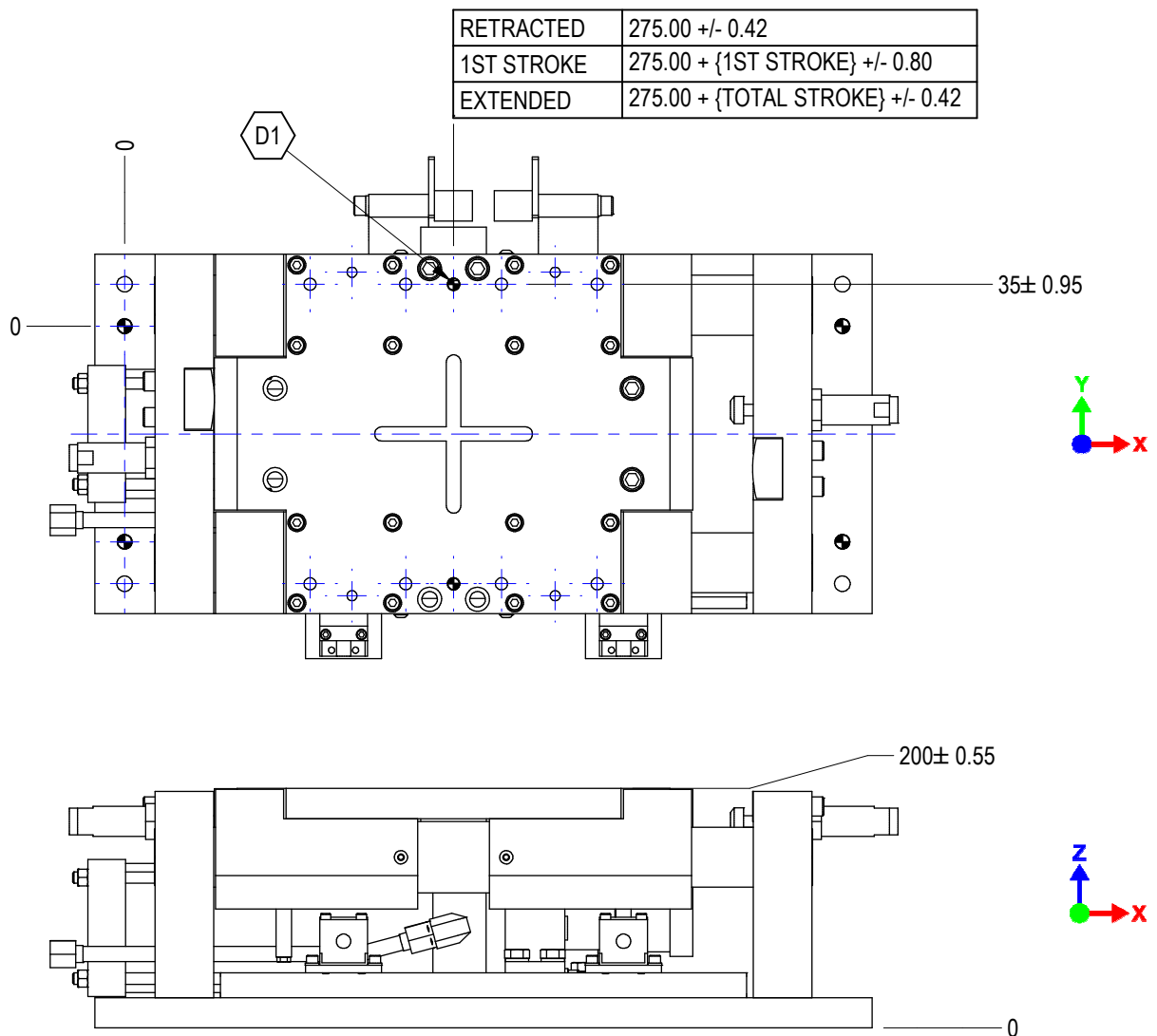

TRAVEL ACCURACY (RUNOUT)	
Y-DIRECTION	Z-DIRECTION
0.45	0.60

(DO NOT SCALE DRAWING)



ENGINEERED PRODUCTS

(800) 229-0890 [www.welkerproducts.com](http://www.welkerproducts.com)

# P7 SLIDE ACCURACY

**POSITIONAL ACCURACY** specifies the allowable deviation between the nominal position of a reference point on the carriage (D1 as shown) to the actual position that is achieved.

**TRAVEL ACCURACY** specifies the allowable deviation along the plane of motion of a reference point on the carriage (D1 as shown) to the actual position *during movement* - in other words, the allowable side-to-side movement (in the direction of Y) and up-and-down movement (in the direction of Z) as the unit travels.

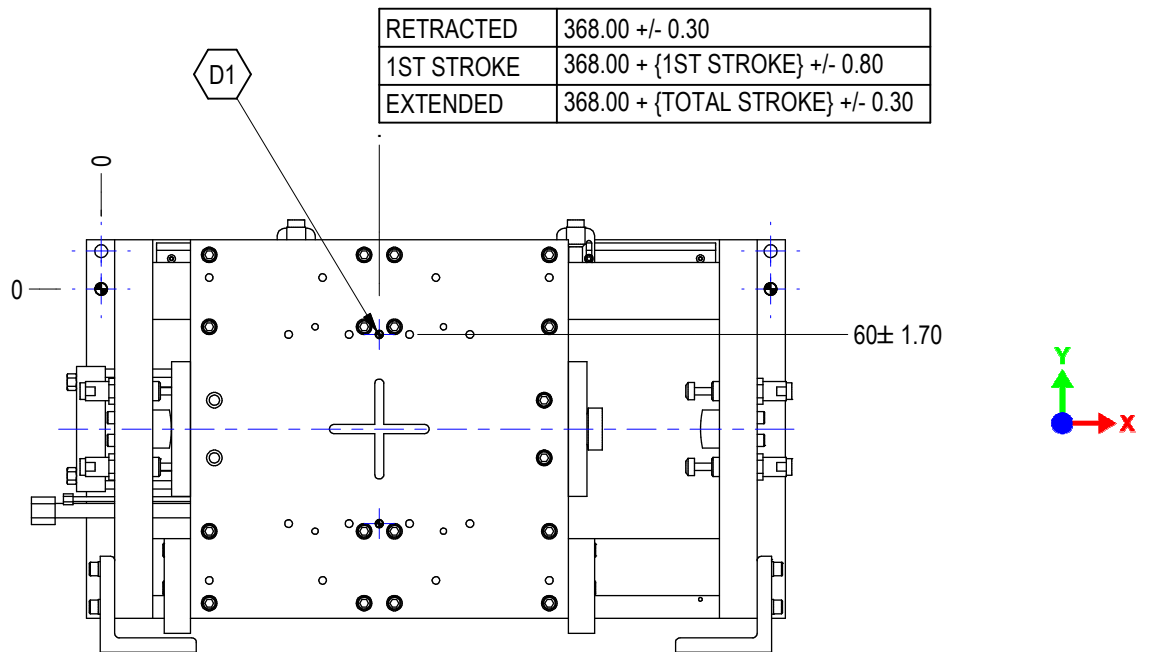

RETRACTED	368.00 +/- 0.30
1ST STROKE	368.00 + {1ST STROKE} +/- 0.80
EXTENDED	368.00 + {TOTAL STROKE} +/- 0.30

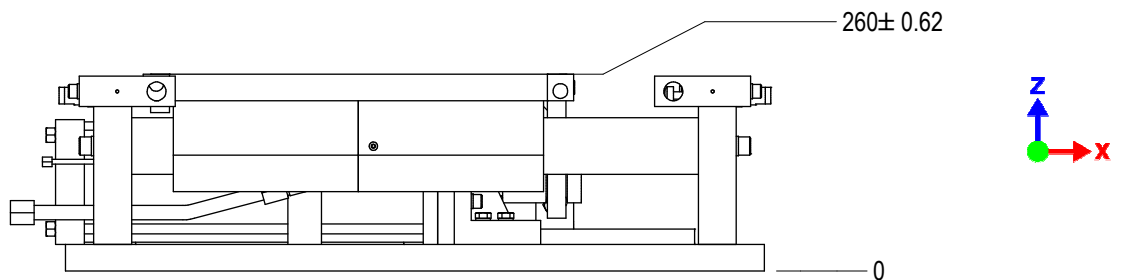

TRAVEL ACCURACY (RUNOUT)	
Y-DIRECTION	Z-DIRECTION
0.55	0.75

(DO NOT SCALE DRAWING)



ENGINEERED PRODUCTS

(800) 229-0890 [www.welkerproducts.com](http://www.welkerproducts.com)

# PAYLOAD & MOMENT LOAD

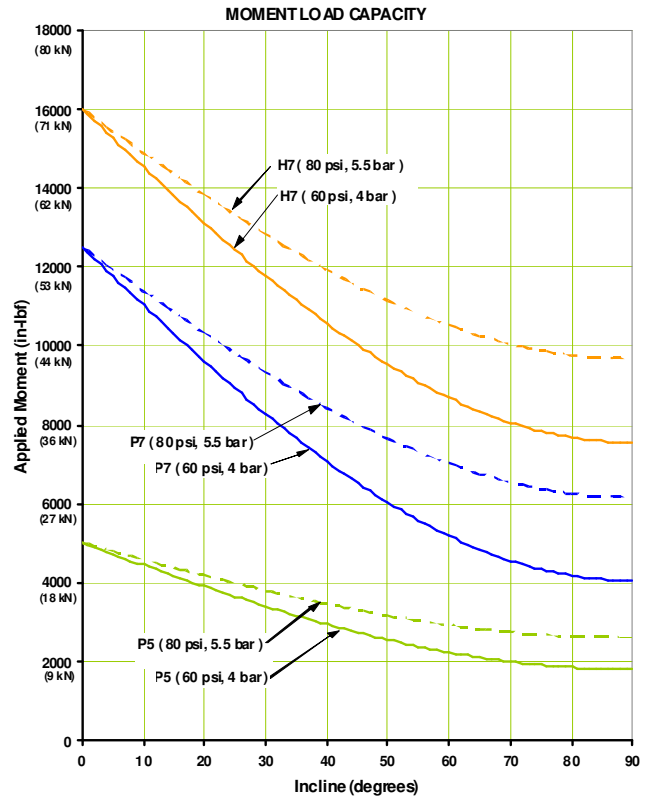
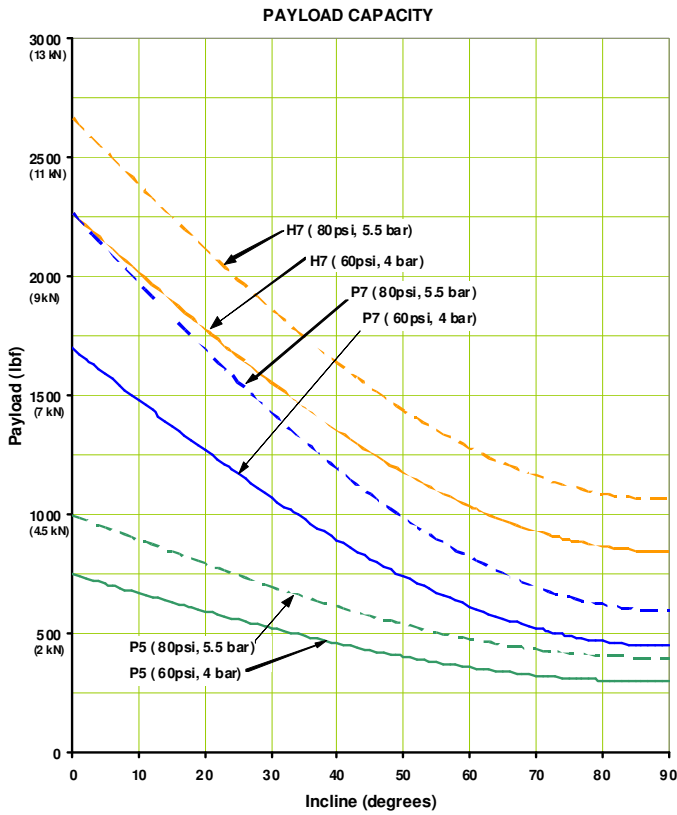

Applications are evaluated in two separate calculations: payload and moment load. An approvable application meets both criteria. For applications outside the graph safety zone, contact Welker.

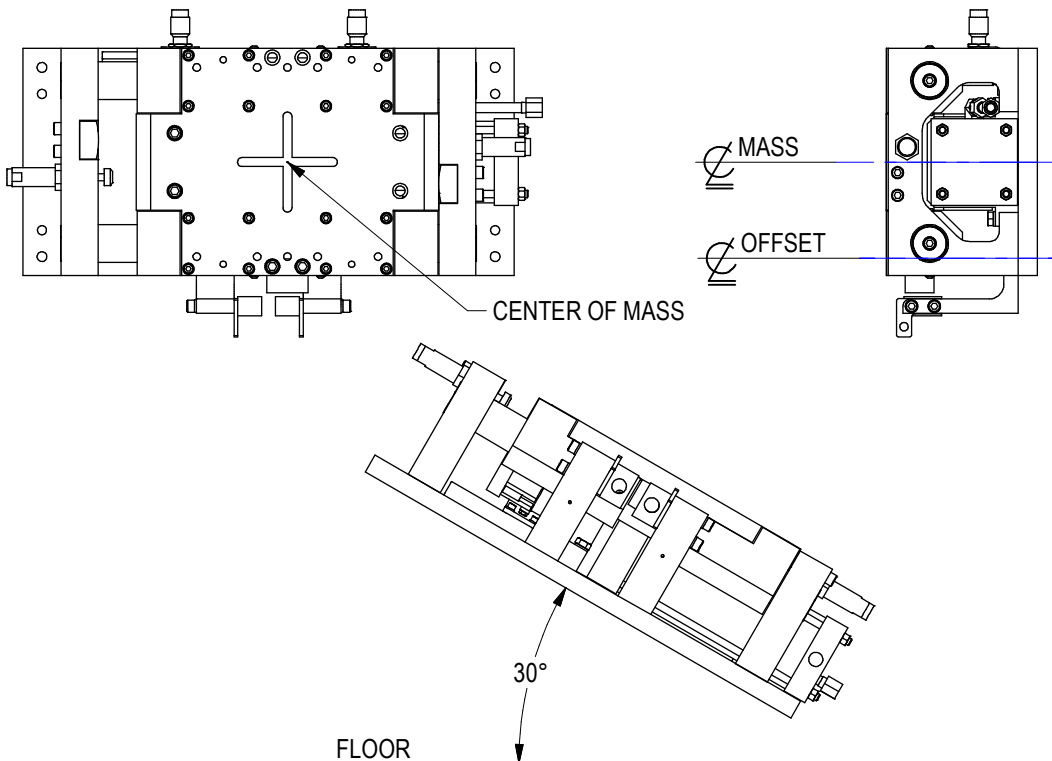

## Loading Example for P5 & P7 Slide:

An application with a 400 lbf (1779 N) payload, offset of 6" and operating at a 30° incline has an applied moment load of 2400 in/lbf. (271 N-m) with an allowable payload of 500 lbf (2224 N). The allowable moment load is 3800 in/lbf (429 N-m). Note that the offset, in inches, is the same regardless of the slide orientation to the floor. Round shafting makes calculations the same for all slide orientations.

(DO NOT SCALE DRAWING)



ENGINEERED PRODUCTS

(800) 229-0890 www.welkerproducts.com