

PIN CLAMP MAINTENANCE MANUAL

PCY

**NON-RETRACT UNIT
(ACTUATOR A)**

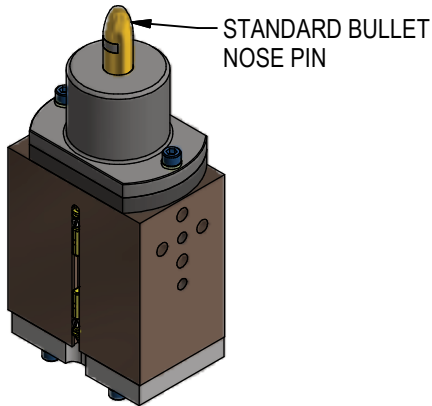

**NON-RETRACT UNIT
WITH SPRING
(ACTUATOR B)**

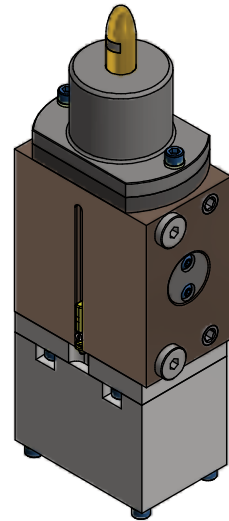

**RETRACT UNIT
(ACTUATORS R/S)**

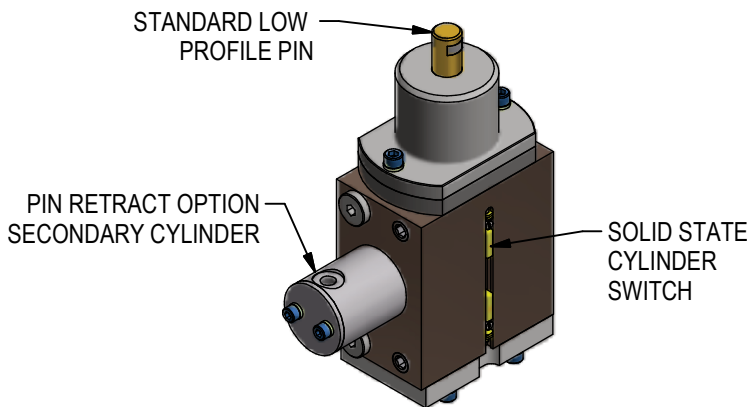

**RETRACT UNIT WITH SPRING
(ACTUATORS T/U)**

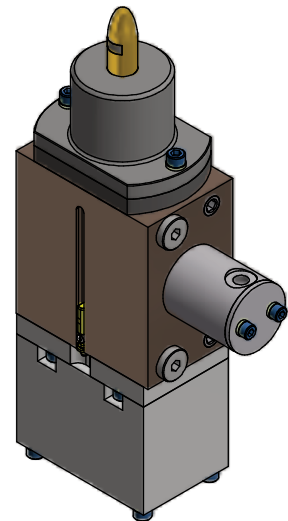

MAINTENANCE

SAFETY FIRST!

MAINTENANCE SHOULD ONLY BE PERFORMED BY QUALIFIED PERSONNEL. PROPER SAFETY GEAR AND PROCEDURES MUST BE USED AT ALL TIMES. BEFORE PERFORMING MAINTENANCE, CUT OFF AIR SUPPLY TO THE UNIT, ENSURE THAT ALL AIR IS REMOVED AND THAT THERE ARE NO "TRAPPED AIR" CONDITIONS.

GENERAL GUIDELINES: NEVER grab pin or fingers with pliers. NEVER strike pin with hammer or pipe. Pin is too small! If part is stuck - pull on part to help cylinder extend and retract fingers.

PREVENTATIVE MAINTENANCE: Regularly inspect unit to verify proper operation. Check for debris build up and clean as needed. Inspect all pneumatic, electrical, and mounting connections, making sure all connections are tight and secure.

CYLINDER: Welker pneumatic cylinder is integrated into PCY unit. Plant air supply to the cylinder should be free of contaminants, filtered to a minimum of 50micron and have a water separator. Be sure fittings are in good condition.

PINS: Pins are subject to wear under normal operating conditions and should be replaced when worn.

SWITCH: Switches may fail and need replacement; it is recommended to keep a spare switch on hand.

Reorder #	Mfr. Part Number	Manufacturer	Description
SWITCH L3	SWITCH L3 (weld field immune, comparable to World Switches)	Welker	4-Wire, 4-Pin, DC M12 X 1 (PNP) Quick Disconnect
SWITCH L5	MK5113	ifm Efector	3-Wire, 4-Pin, DC M12 X 1 (NPN) Quick Disconnect

Standard Switch Option - All other options may affect price and delivery

TROUBLESHOOTING

Failure	Possible Cause	Solution
Pin clamp does not clamp or unclamp	Insufficient air pressure	Check/confirm air pressure
	Contamination build up on clamp fingers	Regularly clean particulate from unit by cycling pin up and down while applying compressed air. Do not use oil or lube. Replace pin cartridge if needed.
	Cylinder	Repair or replace unit
Pin fails to extend Pin & fingers remain retracted	Too tight of fit on part hole	Proper pin size: 0.25mm minimum clearance for geo applications; 0.5mm for material handling.
	Side load too high from improper shimming.	Correct shims to fit metal.
	Side load too high due to part shift when welding.	Better part control during process.
Clamp fingers do not actuate	Contamination build up on clamp fingers Fingers worn	Regularly clean particulate from unit by cycling pin up and down while applying compressed air. Do not use oil or lube. Replace pin cartridge if needed.
	Part rest (backup) worn	Inspect under regular scheduled maintenance. Wear item. Replace if needed.
Broken or worn locating pin	Improper application. Misalignment of tooling-to-part.	Inspect under regular scheduled maintenance. Wear item. Replace pin cartridge if needed.
	Loose pin clamp mount to main bracket	Check pin clamp mount
Switch failure	Switch failure, loose wire	Check switch for proper operation and connection. Replace switch if required.

REPLACEMENT PIN CLAMP CARTRIDGES

SEE CATALOG FOR PIN TYPES AND FINGER ORIENTATION



Pin Diameter
16.01 - 26.00 to 2 Decimal Places

- Pin Type**
- A Bullet Nose Pin with fingers at 0°(Shown)
 - B Bullet Nose Pin with fingers at 90°
 - E Low Profile Pin with fingers at 0°
 - F Low Profile Pin with fingers at 90°

- Actuator**
- A Dbl Acting
 - B Dbl Acting w Spring
 - R Dbl Acting w Retractable Pin (Ports @ 90deg)
 - S Dbl Acting w Retractable Pin (Ports @ 0deg Shown)
 - T Dbl Acting w Retractable Pin & Spring (Ports @ 0deg)
 - U Dbl Acting w Retractable Pin & Spring (Ports @ 90deg)

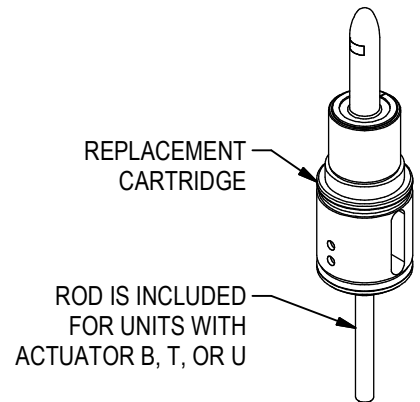

CARTRIDGE REPLACEMENT ~ ACTUATOR A

BEFORE REMOVAL, PIN MUST BE IN THE EXTENDED POSITION AND CLAMP FINGERS BELOW FLUSH.

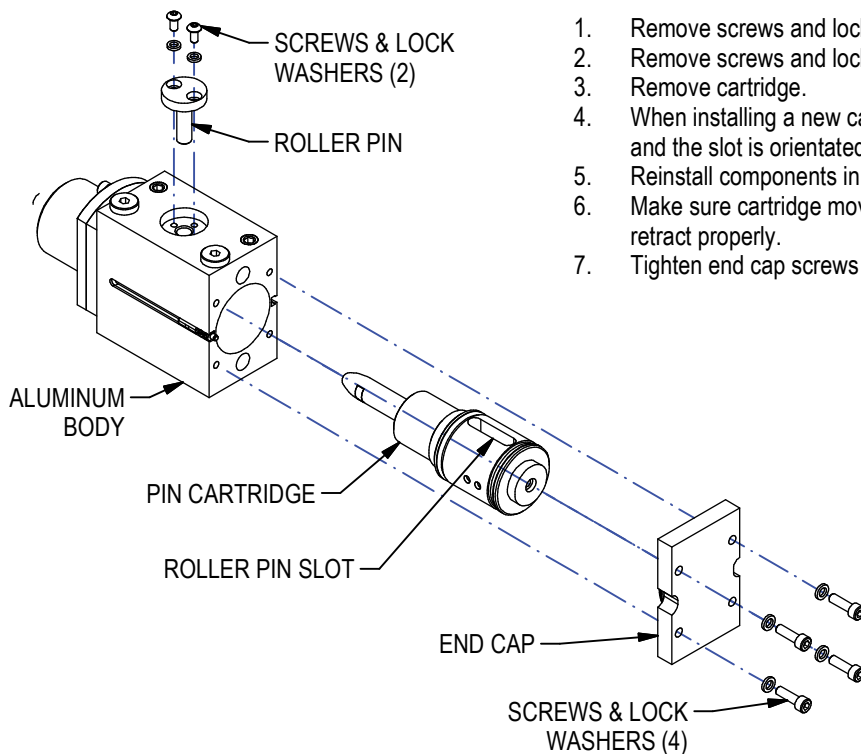

1. Remove screws and lock washers from end cap. Remove end cap.
2. Remove screws and lock washers securing roller pin*. Remove roller pin.
3. Remove cartridge.
4. When installing a new cartridge, make sure the fingers are flush to the pin and the slot is orientated as shown.
5. Reinstall components in reverse order.
6. Make sure cartridge moves freely up and down and the fingers extend and retract properly.
7. Tighten end cap screws to torque shown.

*FOR ACTUATORS R & S

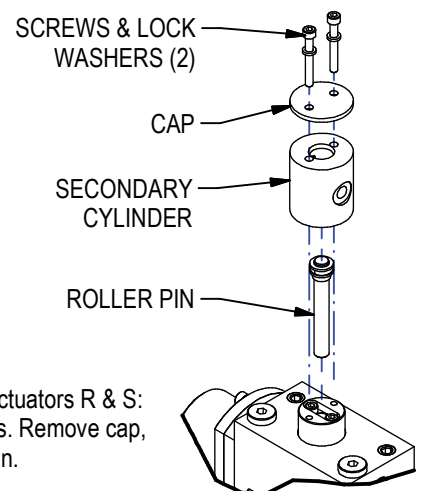

*For units with retract option, Actuators R & S: Remove screws & lock washers. Remove cap, secondary cylinder and roller pin.

Tightening Torques for Metric Bolts (installed dry)				
	Steel		Aluminum	
M5	10 Nm	7.375 ft lb.	5 Nm	3.6875 ft lb.
M6	19 Nm	14.014 ft lb.	9.5 Nm	7.007 ft lb.
M8	45 Nm	33.19 ft lb.	22.5 Nm	16.595 ft lb.
M10	89 Nm	65.643 ft lb.	44.5 Nm	32.8215 ft lb.
M12	156 Nm	115.06 ft lb.	78 Nm	57.53 ft lb.

CARTRIDGE REPLACEMENT ~ ACTUATOR B

BEFORE REMOVAL, PIN MUST BE IN THE EXTENDED POSITION AND CLAMP FINGERS BELOW FLUSH. MAINTAINING AIR ON THE CYLINDER HELPS OPERATION, ESPECIALLY WITH A SPRING RETRACT CYLINDER.

1. Loosen screws securing spring box to unit. Remove spring box.
2. Remove screw securing spacer to rod. Remove spacer.
3. Remove screws and lock washers from end cap. Remove end cap.
4. Remove screws and lock washers securing roller pin*. Remove roller pin.
5. Remove cartridge.
6. When installing a new cartridge, make sure the fingers are flush to the pin and the slot is orientated as shown.
7. Reinstall components in reverse order. Use removable thread adhesive when installing spacer screw.
8. Make sure cartridge moves freely up and down and the fingers extend and retract properly.
9. Tighten end cap screws to torque shown.

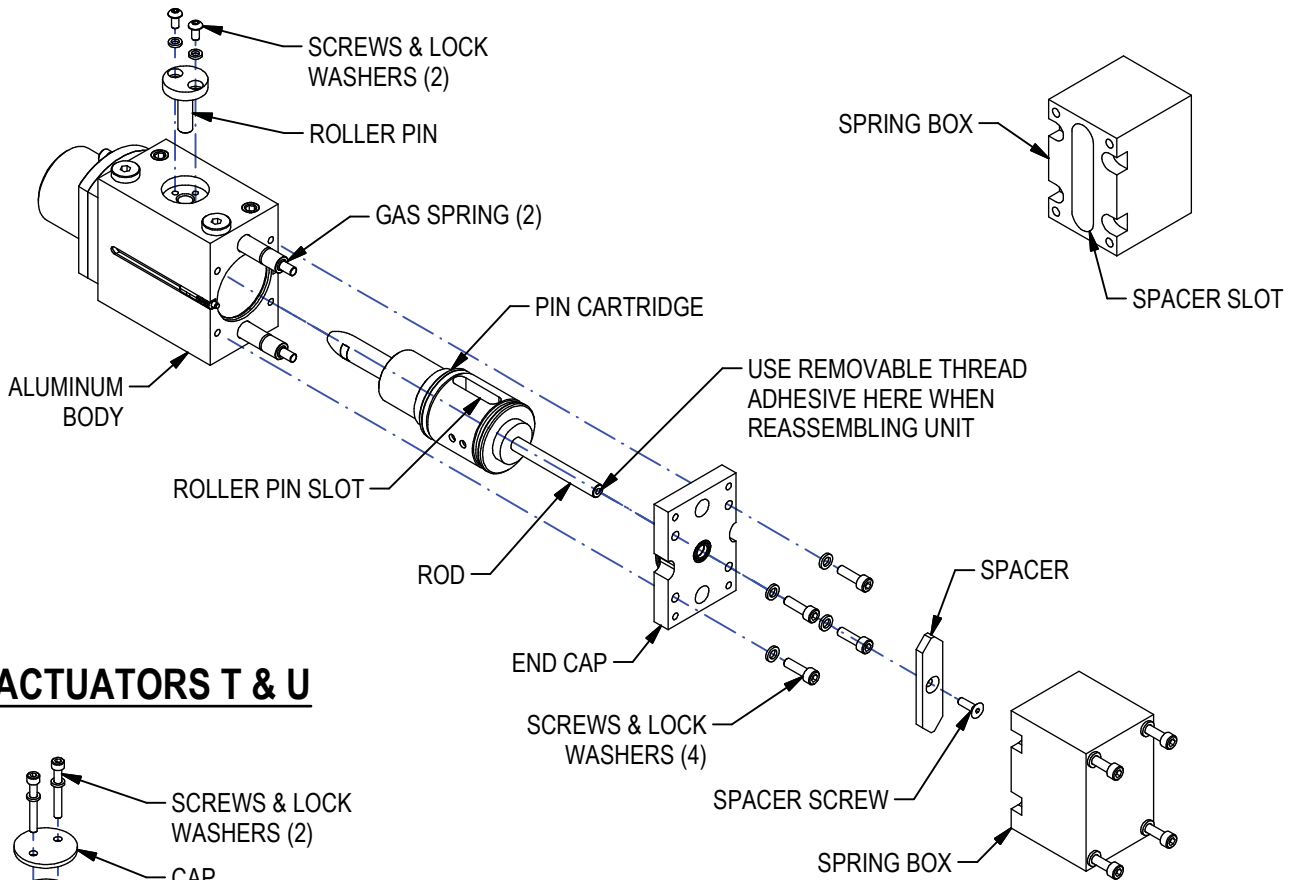

*FOR ACTUATORS T & U

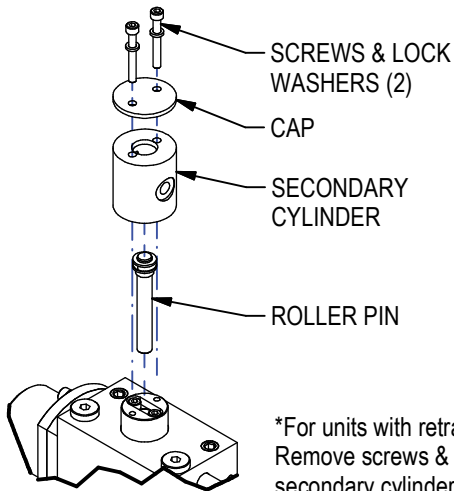

*For units with retract option, Actuators T & U: Remove screws & lock washers. Remove cap, secondary cylinder and roller pin.

	Tightening Torques for Metric Bolts (installed dry)			
	Steel		Aluminum	
M5	10 Nm	7.375 ft lb.	5 Nm	3.6875 ft lb.
M6	19 Nm	14.014 ft lb.	9.5 Nm	7.007 ft lb.
M8	45 Nm	33.19 ft lb.	22.5 Nm	16.595 ft lb.
M10	89 Nm	65.643 ft lb.	44.5 Nm	32.8215 ft lb.
M12	156 Nm	115.06 ft lb.	78 Nm	57.53 ft lb.