

Product Overview



Shot Pins



Part Positioners



Part Ejectors



Part Presentation Slides



Pin Clamps



DB Guided Slides



Dimplers



Expanding Pins



Floating Pins



Gib Assemblies



Ground Blocks



Hook Clamp



Lifters



Lockouts



Mini Locating Pins



Pallet Stop



Servo Shim



Slides



Transfer Pin



Tube Clamps



Wire Clamp



Bearings



Friction Rollers



Smart Stops



Switches



Custom Products



Flexible Automation Components
welkerproducts.com

Shot Pins

Welker's most versatile and durable automation component, used as retractable locating pin, part stop, probe slide, wedge lock, escapement, backup, or straight acting clamp.



UB Series

WP Series

SB Series

- Welker Shot Pins require minimal maintenance.
- Resistant to corrosion and weld spatter.
- Steel & aluminum construction is structurally strong and durable yet lightweight.
- Safety orange steel shrouds are standard on all units, protects seal from weld spray.
- All Welker Shot Pins are NAAMS compatible.

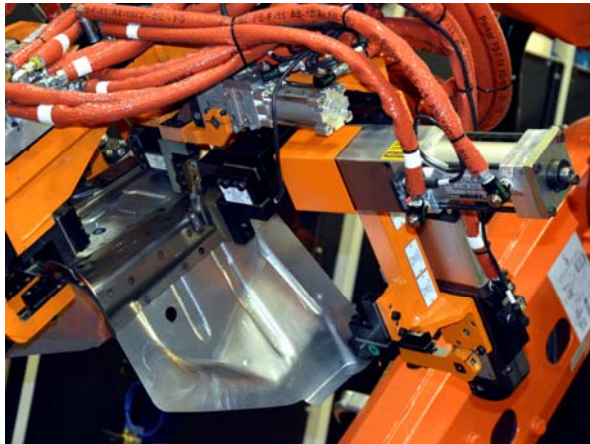

UB4 on end effector in weld cell



Shot Pin in assembly line - still running strong after 10 years

The Welker Advantage

NO LUBRICATION REQUIRED!

Welker shot pins provide long term accuracy & repeatability for precision location

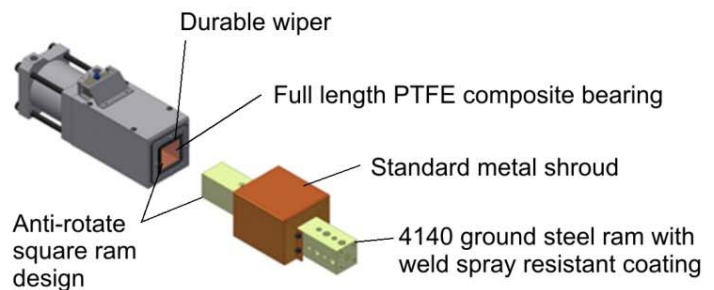

Flexible Automation Components
welkerproducts.com

Bull Pin HP5

Retracting locating pin with a 2kg slide hammer piston. Rap action provides concentrated pulling power. A greater than four times shaft diameter to bearing length ratio is always fully engaged, offering long precision life. No maintenance or greasing required!

Welker trademark simplicity: Bull pin unit has a total of 15 components, including seals and switches
Save money and time with commercial components

Bull Pin Features:

- Chrome plated shaft is 100% continuously engaged in bearings
- Durable urethane scraper keeps weld spatter out
- Anti-rotate feature is completely sealed from contamination. Allows mounting of 2-way pins and crowder pads.
- High-load PTFE composite bearings at both ends, 9" spread. A higher working load capacity than bronze or steel.
- Lubrication free
- Cylinder is piloted to steel weldment body ensuring perfect alignment
- Rap coupling with 2kg slide hammer piston
- Urethane bumpers minimize noise
- Solid state cylinder switch or world clamp switch
- Secure, easily accessible pin mount can also be used to mount crowder pads, etc.

Applications: Frame lines

Bull Pin shown with pneumatic cylinder and weld field immune cylinder switch:



*Bull Pin shown with hydraulic cylinder
And world switch:*



Optional mounting assembly for horizontal and vertical shim adjustment:



Manual operation Bull Pin:



Part Positioners

Install as part pre-loader or as final positioner. Inline lift clears the tool prior to tip out

- *Compact design with cam actuated mechanical motion: 2 motions, 1 cylinder*
- *Treated steel tip plates provide weld spatter and corrosion resistance for durable operation in extreme environments.*
- *Multiple port positions for easy plumbing and installation*
- *Choice of solid state cylinder switch, World Switch, or V-block switch*
- *US Patent 6,918,280 B2*

Position & Clamp

Cam action rotates LST tip plate then clamps down vertically 45mm.

Multiple tip angles available:
11°, 22°, 31°, 39°, 45°

V-block ensures repeatability.



LST



SST

Tips 30°, Clamps 21mm



MST

Tips 30°, Clamps 25mm

Heavy Duty LST S01769

Ideal for applications that require the actuator to net or form the product to the stationary backups.

2200 in lb max torque.

Shown with tooling, in a framing line application



*All positioners require application approval!
Please see catalog*

Part Ejectors

Cuts material handling time by 50%

- *Compact design with cam actuated mechanical motion: 2 motions, 1 cylinder*
- *Treated steel tip plates provide weld spatter and corrosion resistance for durable operation in extreme environments.*
- *Multiple port positions for easy plumbing and installation*
- *Choice of solid state cylinder switch or World Switch*
- *US Patent 6,918,280 B2*

Lift & Eject

Provides ergonomic part cycling – operator can comfortably and quickly load & unload production cell.

Utilizing cam action, the UPE lifts 50mm vertically, then tips out at the specified angle.

Multiple tip angles available:
11°, 22°, 31°, 39°, 45°



UPE



SPE

Tips 30°, Lifts 25mm



MPE

Tips 30°, Lifts 30mm

For additional height

Add up to 150mm to standard ejector lift with the DB4.

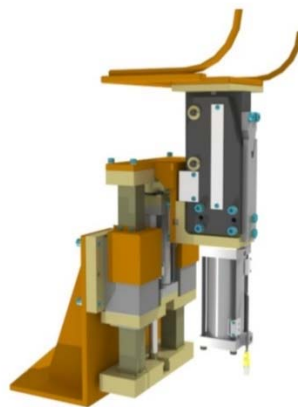

*All ejectors require application approval!
Please see catalog*

Part Presentation Slides

The Welker Part Presentation Slide offers a cost and space saving alternative to conveyors. The slides utilize electric actuators, which deliver a 90% reduction in energy usage compared to long stroke pneumatic slides.

“Move the part, not the robot”

Features:

- Lead screw, ball screw or belt drive
- Rigid heavy-duty extruded aluminum frame with 35-series rail & bearings
- Geared motor options: 1 or 3 HP VFD, servo.
- Optional VFD panel box
- Zerk lube access or auto-lube option
- Extremely flexible and reusable
- Replaces feed conveyors at a fraction of the cost

Operator Benefits:

- Single operator can tend multiple presentation slides, reducing load time
- Safer than indexing or accumulating conveyors

Applications:

- Nested part presentation
- Dunnage bin or cart presentation
- End effector storage/retrieval
- Weld or clinching guns
- Overhead shuttle with DB4 lifter
- Tip dresser shuttle
- Replace conveyors at much lower cost

*AES Standard, screw drive
Available in single, double, double independent and push/pull configurations*



*MES, a mini version of AES Standard
Compact belt drive units for light duty applications*



*Belt drive units for long strokes, up to 10m.
Single or push/pull configurations*



Pin Clamps PCS, PCT & PCM

Welker Pin Clamps offer positive part location and clamping. With the dual finger design, clamping is achieved on both sides of a hole or slot. Maximizes work access to part.



Patent # 6,786,478

- The unique gapless finger design keeps contaminants away from the internal mechanism.
- Linear clamping ensures positive clamping for multiple parts, flanged holes and part thicknesses within a 7mm range.
- Hardened steel locating pin, bullet nose is standard. Low profile, 2-way & 4-way round. Custom shapes available.
- World switch compatible.
- Applications: underbody fixtures, end effectors - replaces separate pin and clamp. Ideal for geometry setting or material handling.
- All Welker Pin Clamps are NAAMS compatible

The only pin clamp on the market with a replaceable cartridge for cost savings!



Patented Dual-Finger Design

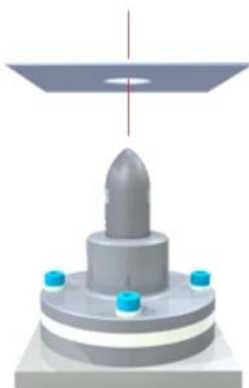

Locate

Positive part location, suitable for pierced or flanged holes

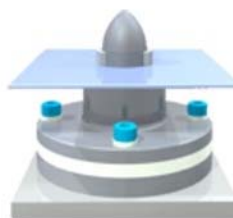

Clamp

Pin retracts, dual fingers extend



Flexible Automation Components
welkerproducts.com

Pin Clamps PCZ & PCY

Compact design with integrated pneumatic cylinder

Provides clamping pressure for up to 4mm part thicknesses, eliminating custom back up machining required with hook clamps. Unlike hook designs that only keep the part from falling off, Welker's dual flush fingers provide easy load/unload and real clamping pressure on both sides of the hole.



Size comparison:
PCZ pin clamp next to a
standard Welker pin clamp

Dual-Finger Design

Locate: Positive part location, suitable for pierced or flanged holes

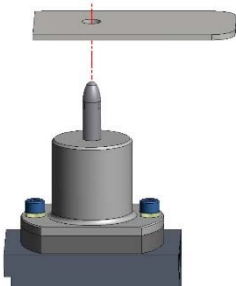

Clamp: Pin retracts,
dual fingers extend

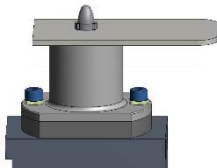

- The unique gapless finger design keeps contaminants away from the internal mechanism.
- Linear clamping ensures positive clamping for multiple parts, flanged holes and part thicknesses within a 4mm range (standard backup). Custom backups allow up to 14mm part thickness.
- Bullet nose or low profile pin style.
- Solid state cylinder switch.
- Applications: End effectors - replaces separate pin and clamp.
- Ideal for material handling.
- PCY retract option allows low profile pin to disappear into unit, flush with backup, for easy part release.
- Spring retract feature holds parts on end effectors if air loss occurs.

PCY

Pin diameters
8.00mm to
26.00mm



PCZ

Pin diameters
8.00mm to
16.00mm



Replacement pin cartridge
sold separately



Flexible Automation Components
welkerproducts.com

DB Guided Slide/Lifter

Can be mounted in any orientation, allowing it to function as a lifter, thruster, slide, pusher, adjustable side guide, or crowder.

DB's double square ram provides super high rigidity and offers excellent torque resistance. High performance reinforced PTFE square bearing provides permanent lubrication. Standard unit features aluminum body with steel mounting plates and steel square ram. Aluminum unit has aluminum body, mounting plates and ram. DBs use Welker Smart Stop for sensing and shimming both ends of stroke. Optional cylinder switch also available.

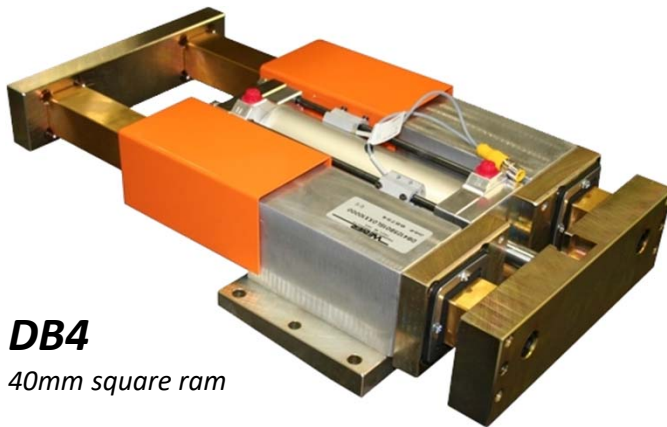

Applications: High torque nut-runners, overhung loads, weld gun tooling & locating feature nests.

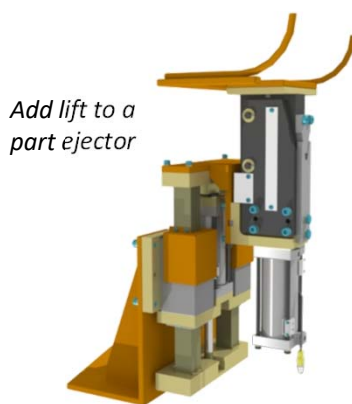

DB as a lifter with extrusion slide in pick & place application

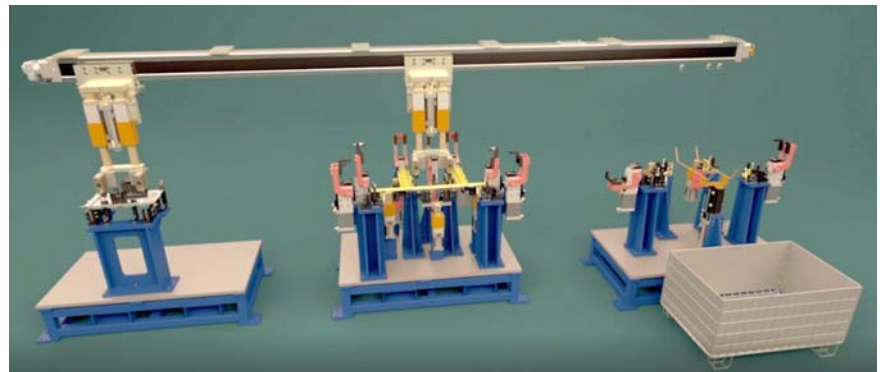

Auto-Indexing Dimpler WD3

Welker Auto-Indexing Dimpler prevents sheet metal blanks from sticking together in stamping operations by producing small dimples in the trim edge that automatically index with the action of the press.

- 7 indexes per revolution minimizes potential for dimple nesting
- Protects dies by minimizing potential for multiple blank feeds
- Can correct fan stack effect on tailor-welded blanks
- Requires no air, hydraulic or electrical connections
- Actuated by gas spring for superior reliability
- Increases efficiency of part transfer systems
- Suitable for aluminum or high strength steels



Dimples not included – contact Welker for availability

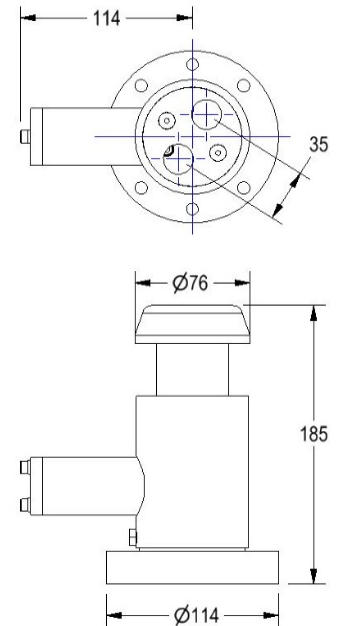

Auto indexing dimpler guarantees space between consecutive parts

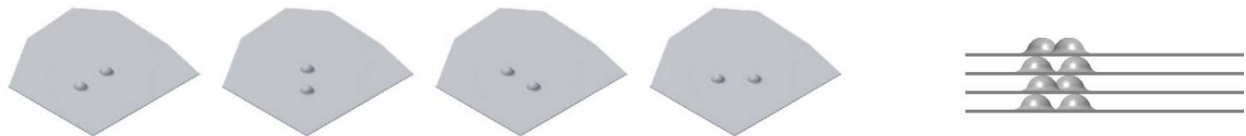

Auto indexing dimpler guarantees space between consecutive parts

Level tailor-welded blanks with dimples:



Fanned stack, no dimples:



Roll Dimpler

US Patent #10,328,470 B2

The Welker Roll Dimpler minimizes blanks sticking by adding rows of small dimples to sheet metal in coil fed operations. The compact design mounts between the decoiler/straightener and press. Dimples prevent blanks from sticking together, simplifying handling for operators and press feed robots. Minimizing double-sheet misfeeds prevents machine damage and downtime. Eliminates the need for expensive air knife systems. Ideal for nonferrous materials where fanner magnets are ineffective. The roll dimpler can be used with any coil fed material.

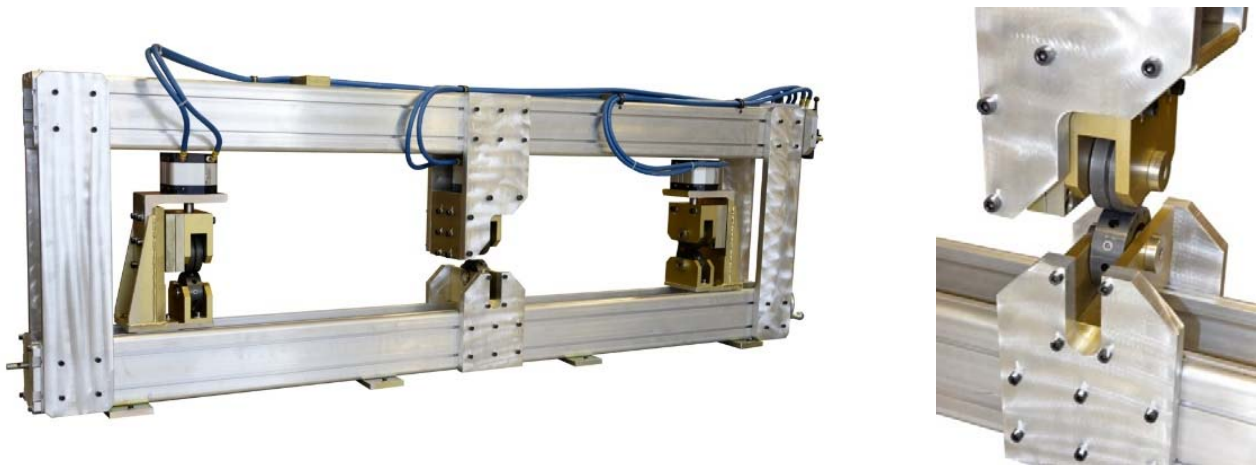

Unit is typically supplied with three adjustable dimpler heads to accommodate any width of coil

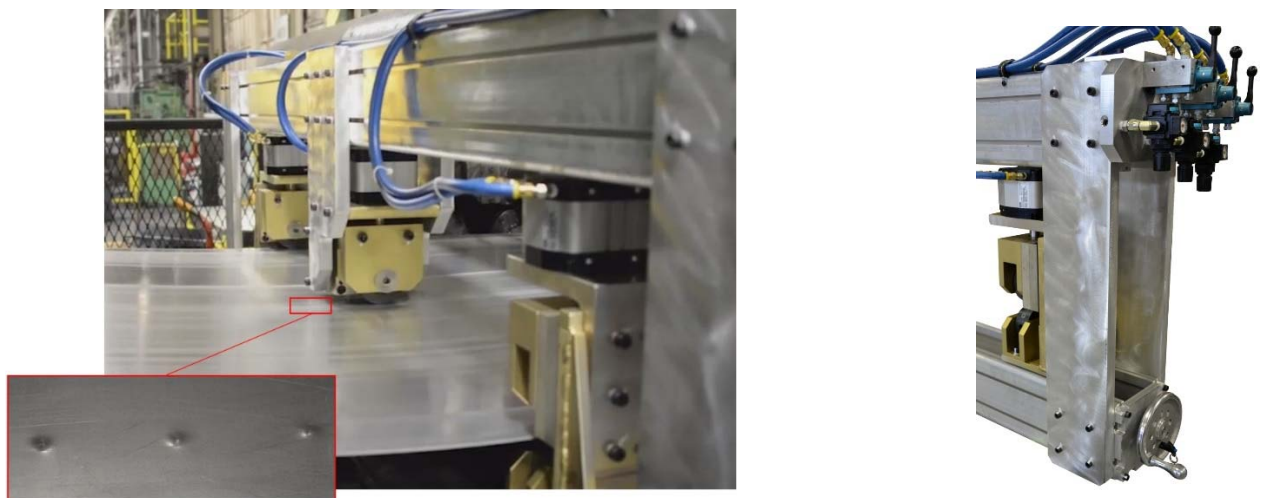

Expanding Locating Pins

- Capable of locating large and heavy fabrications.
- Provides for easy load and unload of work piece, allowing complete access to the part.
- Also used to center loose tolerance diameters in tubes or plate.
- Pin diameters 30 to 200mm
- Multiple finger arrays, 2-way and 4-way location
- Conical, flat, or bullet nose pin options. Special geometry available: square, rectangular, etc.
- Optional solid state cylinder switch



Expanding pins are custom engineered to specific application requirements

Double support pins



Multiple finger pins



Bullet nose pins

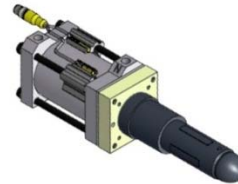

Stepped finger pins



Locate & Center

After part is located on the pin, the actuator causes the fingers to expand, serving as an internal concentric clamp for accurate and repeatable part positioning.

Mechanical advantage keeps the fingers in extended position until actuator retracts.

Can also be used in post-machining bore separation applications.

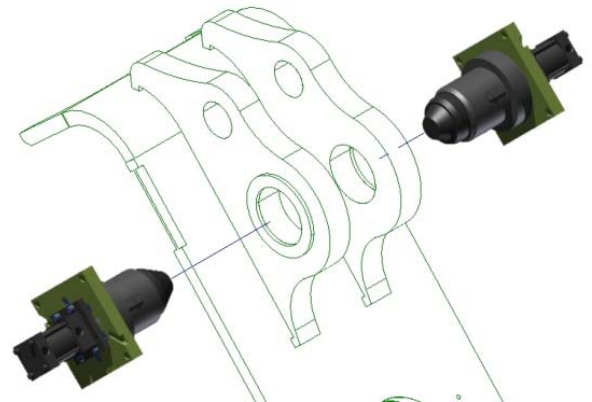

Floating Locating Pin

The Welker Floating Pin provides a rigid 4-way pin and net surface for geometry setting. The only component that will allow multiple 4-way pins on the same part without hole damage or pin wear. 10X more repeatable than any retracting pin.

Features:

- When pneumatically released, floating pin has a 2 or 3mm radial float and can rotate up to 25°
- Sealed to resist contaminants
- Bind-free part stripping
- 15-40mm NAAMS pin compatible, optional backup. Custom pins also available
- Flat mount style can float other devices such as rest & nesting blocks, geo backups or datum blocks. No need to dump or retract.
- Solid state cylinder switch option
- Spring extend option maintains fixed centered position on tools with operator interface



FP2 2mm radial float

FP4 3mm radial float

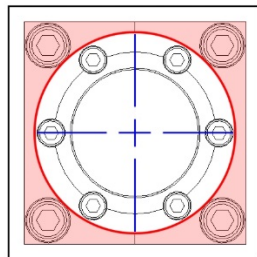
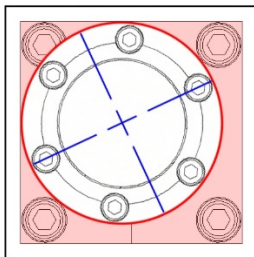

Floating feature allows horizontal pin movement and rotation up to 25 degrees when in released position. Pin orients and returns to center when cylinder is actuated.

Applications:

Fixtures and end effectors. Eliminates pushers from geo end effectors. Especially useful in aluminum welding where there is significant part movement.

Gib Assemblies & Waystrip

Bonded gibs and wear plates are a cost effective product for providing a lubrication free method of movement. Wear plates and gib assemblies utilize high performance materials bonded to metal substrates to provide strength and a low friction surface. CIP laminate or reinforced PTFE can be bonded to steel, stainless steel, bronze or aluminum.

Bonding Services ~ Over 30 years experience!

Bonding of composite material is processed at our 3500 sq ft bonding Troy plant. Welker's facility features three heated bonding presses, up to 24 x 58", and a bonding oven 60 x 84 x 48" deep. Rulon®, Rulon® F, PTFE, Metaloplast, and CIP material available for custom bonding to new parts and fabrications, machine way repair, and rebuilt machines.

Gib Assemblies

Linear slides and gib assemblies feature a bonded construction of Rulon® and steel, providing both strength and permanent lubrication.

Non-standard sizes and special lengths available. Gibs are provided either without holes or with standard hole patterns.

Hardness: RC 35 minimum

Finish: Ground 8-16 RMS in direction of travel or Electroless Nickel plate or hard chrome to .0002 minimum thickness.



Bonded gib slides for flash welding application: automotive battery terminals to cables

Fabricated Wear Plates & Waystrip Material

Stroke Increment: 5mm

Maximum Stroke: 1000mm



Ground Block Retracts

For all MIG and arc welding applications in fixtures, trunnions, and dial tables. Insulated ground block cylinders are ideal for single-point welding. Produces a consistent pressurized ground even after significant electrode wear. Increases weld consistency.

Retractable ground blocks allow easy part removal or transfer. Cylinder rod is electrically insulated from body. Weld field immune cylinder switch is adjustable to sense extend and retract. Standard copper shunt adaptor allows easy shunt connection.

- Fits standard #2 MT taper swivel tips
- Bi-directional body mounting; floor or remotely mounted
- Lubrication free design
- Eliminates commutator grounds on trunnions
- Cost advantage over machined backups/ground blocks
- NAAMS compatible
- Part contact pressure can be adjusted with inline regulator



S02645
Pivoting GB2



GB2
25, 50mm
strokes



GB3
25, 32, 50, 75,
100mm strokes

Spring Extend Ground Block

Ideal for end effectors - no actuator required, mounts directly to tooling. Nose is out in normal position. Optional Class 2 copper swivel head adapter assures positive contact.

- 12mm stroke, 15 lb extend/46 lb retract compression spring
- Base is electrically insulated from shunt mount
- Full length lube-free bearing, double seals, chrome plated slide shaft



S01353

Pass Thru Ground Blocks

Fully insulated, compact units that move the grounding cable away from the contact face. Pneumatic and spring actuated versions provide consistent pressure for weld consistency.

- Class 2 copper rod electrically insulated from mounting block
- Standard copper shunt adaptor allows easy shunt connection
- Lubrication free design
- Eliminates commutator grounds on trunnions
- Cost advantage over machined backups/ground blocks
- NAAMS compatible



GBP

Pneumatically actuated
#2 MT taper swivel tips
Includes adjustable Welker L3 switch
to sense extend and retract

GBS

Spring actuated
#2 MT taper swivel tips



GBM

Spring actuated
#1 MT taper swivel tips
Side or end mounting body styles

Hook Clamp

Compact clamping motion for low clearance conditions

Features:

- Single-sided J-action hook clamp
- Optional spring return keeps unit clamped during air loss
- Custom sized hook arms available
- Weld spatter resistant surface
- Solid state cylinder switch or Welker Smart Stop

Applications: Edge clamping, end effectors

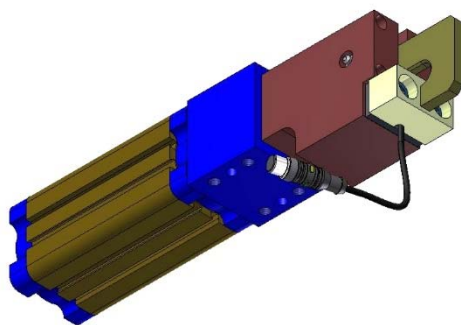
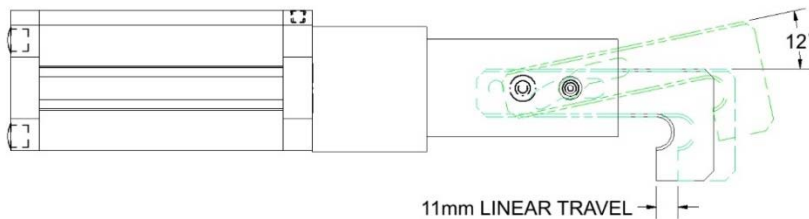

*Hook clamp shown with
optional backup and
Welker Smart Stop*

Lifters

Compact closed height, no need for costly floor pits. Unique design is always the same height as cylinder when retracted.

- High repeatability. Versatile mounting options - symmetrically reversible, can lift overhung loads.
- Strokes up to 1000mm
- Pneumatic, hydraulic or electro servo actuators
- Maintenance free operation! Completely lube-free PTFE bearing, hard chrome plated shaft



Optional Servo Synchronizing

Synchronizes remotely mounted units. Simultaneously lifts from multiple points allowing better accessibility to work area in center of tool.

Lift Tables

- Heavy duty 4-post steel lift table.
- Pneumatic, hydraulic, or electric actuator.
- Lift height and plate sized to suit.
- Ideal for lift & transfer applications.



Lockout Pins

Single Shear Spring Extend or Double Acting Pneumatic Lockout

Features:

- Pneumatic retractable pin packages with an optional spring extend. Air loss triggers mechanical pin extension.
- Optional solid state cylinder switch
- Tapered pins provide accurate positioning for trunnion units or rotary tables
- Convenient and easy to mount
- Promotes safe machine operation & maintenance
- Saves production downtime by preventing crashes
- Low maintenance!



Lockout Load Capacities		
BP1 1/2" pin: 500 lb	BP2: 2,500 lb	BP4: 5,000 lb
BP1 3/4" pin: 750 lb		

Flat Nose Lockout

Use with clearance receiver



Conical Nose Lockout

Use with 2-way & 4-way receivers



Double Shear Lockout Unit

Allows for 10,000 lb side load capacity
 Suitable for automatic or manual tooling
 Optional spring extend with air loss
 Corrosion and weld spatter resistant surface

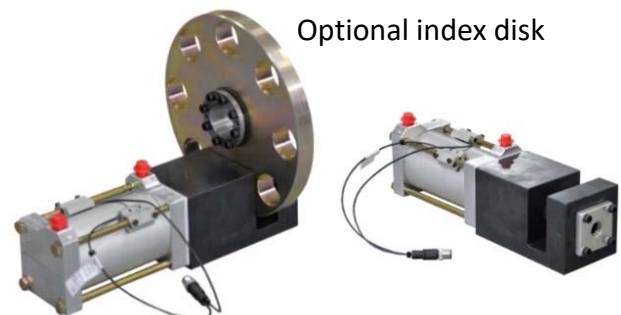

Mini Retractable Locating Pins

Welker Mini Pins are the perfect fit for compact spaces and applications with limited accessibility. Inline and offset units for maximum design flexibility and repeatable, precision part location. Ideal for seating, end effector, instrument panel, exhaust, and trunnion applications.

Features:

- Net surface & primary pin locator are combined into one component.
- Versatile NAAMS mounting on two sides. Can be used as an extension of the tool.
- 2-way or 4-way locating pins up to 25mm diameter for in-line units and up to 19mm for offset units.
- Hard anodized aluminum construction, weld spatter resistant coating.
- Easy pin change-out. Pins are interchangeable between inline and offset: lower spare parts stocking costs.



MPS Inline Mini Pin



MPC Offset Mini Pin

Allows access to very narrow spaces and close hole spacing, to 35mm. Lever-pivot action eliminates binding issues common with other link-bar designs.



MPS palm button option for manual operation

Retracting Micro Pin RMP

For small, lightweight parts with minimal side load

Features:

- Customer-replaceable pin. Round pins only, no anti-rotate
- 12mm max diameter pin fully retracts inside backup
- Welker L3 solid state weld field immune switch included
- NAAMS 8mm dowel with tap & thru multi-sided mounting
- 6mm pin engagement, 15mm stroke
- Rap coupler



**Lightweight unit
weighs just 1.3 lbs**

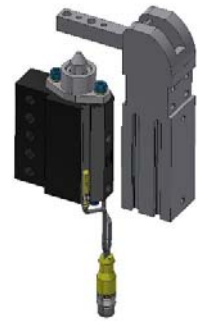

*Clamping
backup*

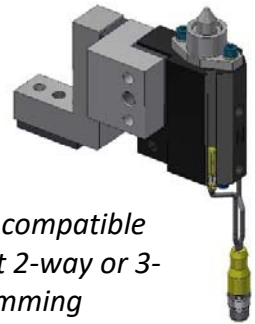

*NAAMS compatible
compact 2-way or 3-
way shimming*

*No seals in backup.
Backup can be machined
away for clearance*

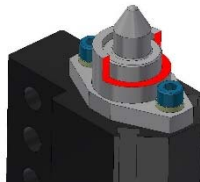

*Can be used without backup.
No pin modification below
shoulder*

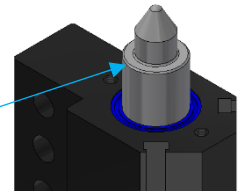

Good applications:

- Metal $\leq 1.5\text{mm}$ thick
- Vertical applications with small parts, pin pointing up
- Multiple metal with one hole being 2-way or clearance
- End effectors: closures, door, hood, deck lid, seating lines
- Non-automotive industries
- Load to extended pin, not a repositioning device

Bad applications:

- Multiple metal with same hole size
- Vertical applications with pin pointing down
- Horizontal applications with heavy parts or where the pinned part becomes part of heavy assembly
- Applications side loads >20 lb on pin

Micro Pin buyoffs must include hole size and tolerance. No flow controls required or recommended.

Floating Micro Pin NMP

Parts are loaded when integrated pneumatic actuator is engaged and pin is centered. When unit is pneumatically retracted, pin has a 1.5mm radial float, reducing pin wear and part bind when unloading part. Floating feature is shielded to resist contaminants.

Features:

- Pins are hardened to RC 48-52, with weld spatter resistant coating
- Pin has a 1.5mm radial float when unit is pneumatically retracted
- Floating feature is shielded to resist contaminants
- Integrated pneumatic cylinder, 28mm bore x 11mm stroke
- 1/8" NPT or G 1/8 ports
- Low profile or cone pin, diameter range: 3mm - 13mm
- Round pins only, no anti-rotate; pin does not retract
- Reduces pin wear & part bind when unloading part
- Includes Welker L3 cylinder switch

Lightweight unit weighs just 1.5 lbs

*Choice of 3 body styles.
Side or end mounting styles are direct replacement for NAAMS pin retainers.
Side & end mounting style is direct replacement for Welker RMP*



Floating Pin sequence of operation:

1. Extend cylinder to lock pin in place.
2. Load product to pin and perform tool operation.
3. Retract cylinder, allowing pin to float.
4. Unload product from pin.
5. Repeat sequence.

Pallet Stop CMX

***Mechanical lock will not fail with loss of power.
Strong enough for zone conveyor emergency stops.***

Features:

- Adjustable cushioned stopping
- Fingertip manual override
- Four arm style choices
- Horizontal or vertical mounting
- Maximum impact 500 LBS @ 30 FPM
- Prox switch (customer supplied) senses stop arm
- Integrated pneumatic cylinder

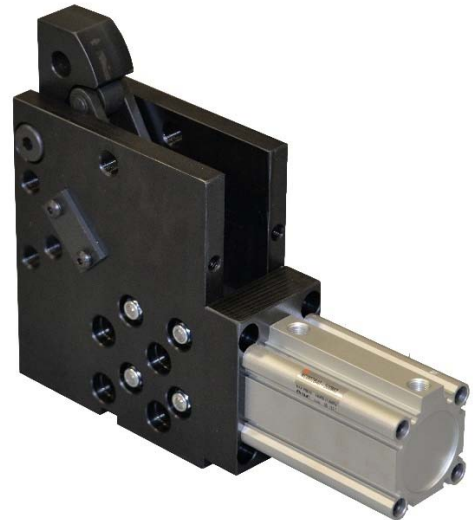

CMX shown with short arm style

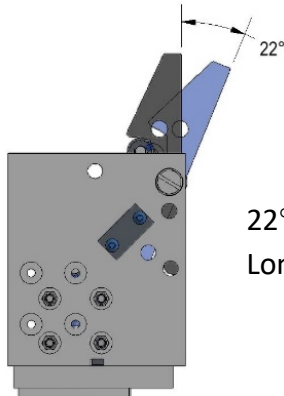

22° approx cushioned decel travel, all arm styles.
Long arm style shown.

Applications:

Free-standing
accumulating
conveyors



Servo Shim Positioner S01474

Maximizes tooling flexibility by allowing quick repositioning of nets for in-process adaption to build trends in metal.

Features:

- Lightweight aluminum construction for end effectors
- Match ground lead screw and nut holds position even without power
- Available with single axis or double axis (shown) configurations
- 1" per second travel speed
- 150 lb load capacity
- Slide travel is 25mm per axis
- Can be mounted in any orientation
- Lube-free PTFE ways
- 24V DC servo actuator with absolute encoder

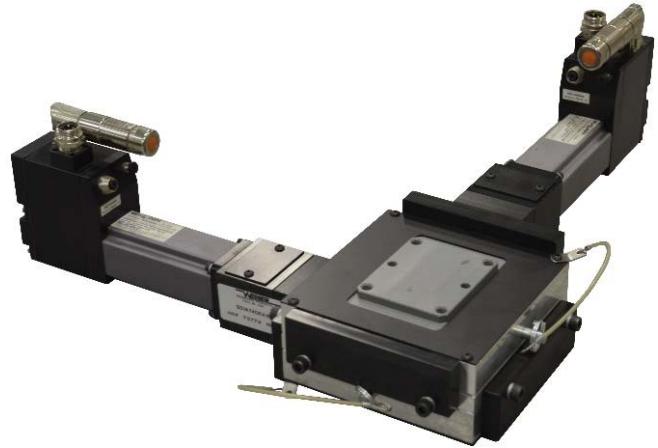

Dual axis S01474

Typical Application

Shown with Welker pin clamp as locator & clamp.
Repositions quickly for build trend change.

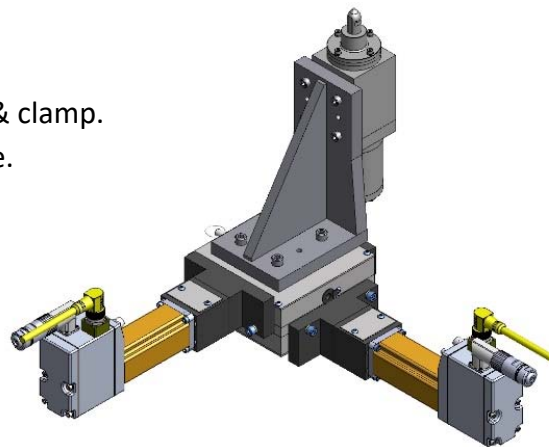

Powered Slides

Welker Slides provide all the desired features that engineers and designers need. The compact, yet robust, powered slides provide symmetry and flexibility of installation. They can be mounted in any orientation and are designed to operate successfully in harsh environments: welding, foundry, sandblasting, machining

Available with non-locking, duplex, locking pneumatic cylinders, hydraulic cylinders and electric servo powered. Pneumatic and hydraulic slides are pre-plumbed for easy installation.

Plane Bearing Slides

Ways are composite bearings, hard chrome shafts, double seals; no way covers are required. Lube free! Least expensive and most durable. 800# capacity



Rail Slides

Standard and low profile configurations for heavy loads. Kevlar shields protect rails from weld splatter, easy to replace. Optional auto-lube. Up to 4000# capacity

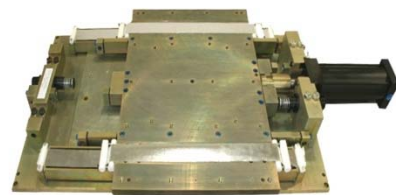

Servo Slides

All slide types can be made as servos to allow infinite precision positioning and a greater capacity to integrate control devices. High level of repeatability.

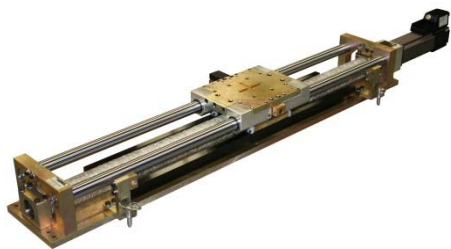

Tool Tray Shuttles

Electric actuators and absolute encoders for high repeatability. Carriage plates are machined to customer hole patterns and feature precision homing/lockout pins.

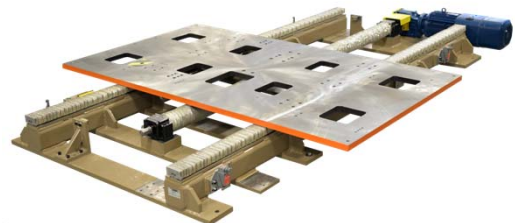

Custom Slides ~ Load capacity and stroke to suit. Contact Welker for help with your application!

LP Series Rail Slides

Lightweight, durable compact slides feature aluminum base and carriage plate

- Stroke lengths: 75, 135, 195, 255, 315, 375, 435, and 495mm
- Shroud runs entire length of unit protecting rails and bearings from contaminants
- Standard NAAMS hard stops. Optional Welker Smart Stops for sensing and stopping
- Solid state cylinder switch option
- Retract and/or extend shims
- Standard NPT or G port pneumatic cylinder
- Can be mounted in any orientation



LPM 250 lb load capacity
Rod lock cylinder option

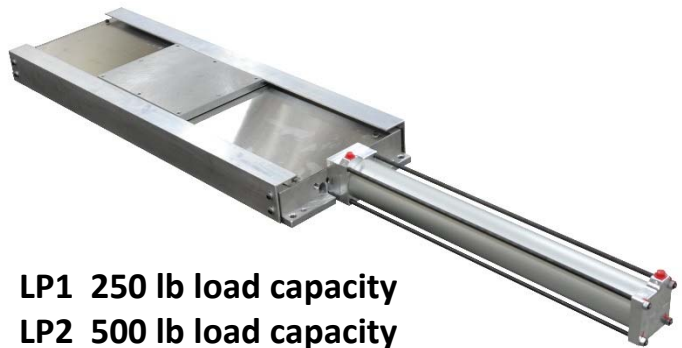

LP1 250 lb load capacity
LP2 500 lb load capacity

Typical Applications

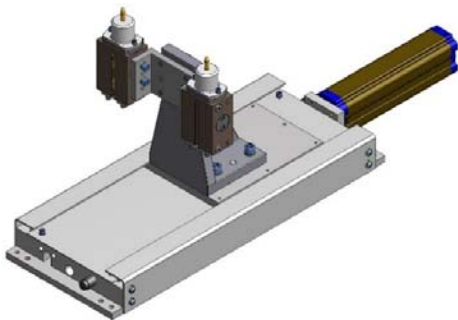

LP1 shown with Welker PCZ Pin Clamps

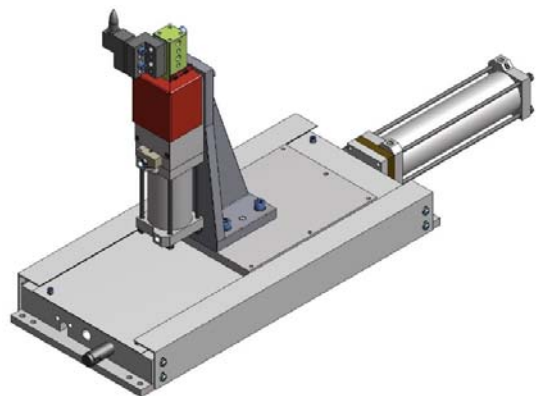

LP2 shown with Welker UB4 Shot Pin 12

Transfer Pin RTP

Concave pin tip meets the fixture's locating pin and maintains spring force contact while part is transferred. Pin-to-pin transfer allows use of the same holes in parts without using nontolerance holes.

Features:

- Lightweight aluminum body
- 8-20mm diameter round pin (only)
- 50mm stroke, spring loaded
- Spring retract during part transfer
- Multi-sided mounting options
- NAAMS swap out ready for use as a robot teach aid

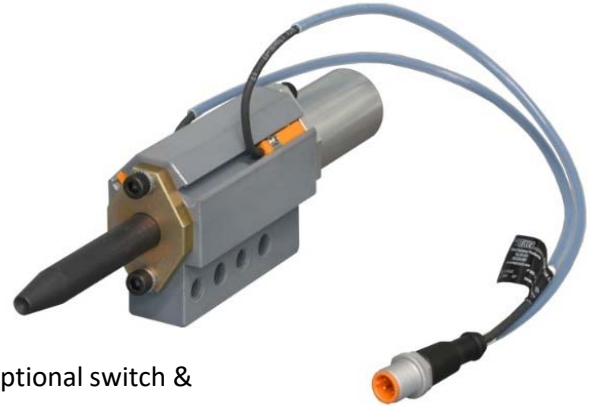

Optional switch & choice of spring pressure

Pin dimple fits NAAMS standard pins

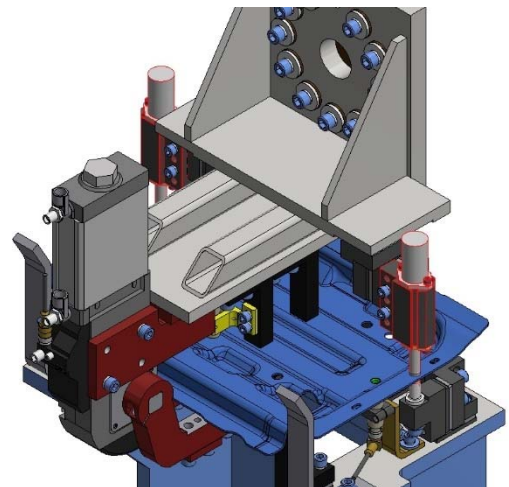
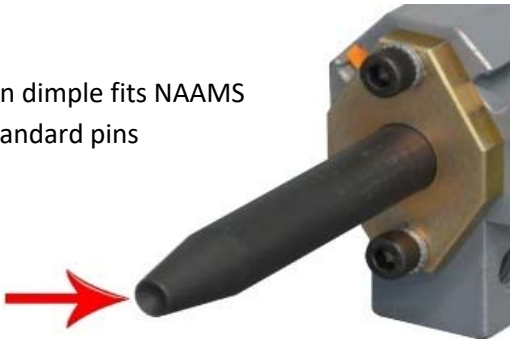

Shown in part transfer application

Good applications:

- End of arm tooling
- Pass table
- Load table
- Material handling
- Pass-off application
- Robot teach aid

Bad applications:

- No-hole
- Parts not clamped
- Pick misaligned
- Pin line-up not the same angle

Tube Clamp

*Narrow back-up and clamp for holding tubing, centers tube securely from both sides.
Allows more weld access than traditional modified clamps.*

- Compact design available in 3 sizes:
 - 1-2" tube diameter
 - 2-3" tube diameter
 - 3-4" tube diameter
- Pre-hardened clamp arms for durable operation
- Pneumatic cylinder with multiple port positions for easy plumbing and installation
- Optional solid state cylinder switch



Applications:

Exhaust systems

Seating

Furniture/chair manufacturing

Tube machining

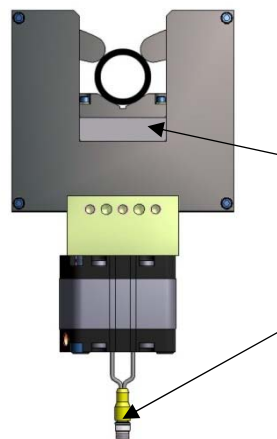

Interchangeable spacer allows multiple diameter tubes in the same fixture (within clamp size range)

Optional solid state cylinder switch

Wire Clamp TCA

For workpiece diameters 3.0 thru 10.0mm

Features:

- Wire is spring retained in load position without air for safe operator load. Cylinder pressurizes clamp, then pneumatic release.
- Lightweight aluminum body
- Multiple NAAMS standard mounting
- Weld spatter resistant coating
- 25mm bore pneumatic cylinder with multiple port positions for easy plumbing and installation
- Solid state cylinder switch, optional
- Hardened steel finger and part contact surfaces

Applications:

Seating manufacture (below)

Instrument panel assembly

Appliance manufacturing

Exhaust systems



Bearings

Welker traditional SAE660 bronze bearings are available in standard sizes or machined to customer specifications. Alternative bearings such as CIP and reinforced PTFE offer built in lubrication, high load/low friction performance and the ability to operate in hostile environments.

CIP Bearings

For high loads, low speed applications. Can run against hard or soft mating surfaces.
Resin bonded fabric with internal lubrication.



Rulon Bearings

Filled PTFE for low load, average speed applications. Does not require lubrication.
Chemically inert.



CJ Bearings & Thrust Washers

Long wearing, maintenance-free bearing suitable for high load/low speed applications.
Low coefficient of friction, chemical resistant.



Fabricated Plane Bearings (SAE 660)

Standard bronze bearings for high load applications. Must be lubricated.
Machined to customer's print/specs.



FCJ & FCJ Precision Bearings

Excellent general purpose bearing for combination motion-oscillatory, linear, and/or rotary applications. Bearings can run against hard or soft shafting.



Bonded Construction Bearings

Provides a bearing surface in otherwise inaccessible areas, can be used for diameters, flat or spherical surfaces. Broad flexibility in size, geometry and location of wear surfaces.



Friction Rollers

Welker friction rollers are powdered metal components designed for economy, long life and maintenance-free performance. Two configurations are available: one-piece roller and a three-piece roller assembly.

One-Piece Roller

The one-piece system runs the hardened roller on a hardened shaft. The roller is generally positioned on the shaft with set collars or spacers.



3-Piece Roller



The three-piece design eliminates the roller riding directly on the shaft, allowing the use of soft shafting. The roller is positioned by pinning the flange and collar to the shaft. The larger roller I.D. provides greater driving force than a one-piece roller.

The three-piece roller maintains a more constant drive force throughout its life. Three-piece rollers are specifically recommended for inclined sections and areas where pallet acceleration from stops is critical.

One-piece and three-piece rollers can be used on the same line where different amounts of drive force are needed.

- *Round or hex ID*
- *2.5" to 3.5" diameters*
- *Urethane coated ODs*
- *Hard chrome plated ODs*



Smart Stop™

*Welker Smart Stop does all stopping & sensing functions in one part.
Minimizes engineering, field set up and operator adjustment time.*



Eliminates:

- Need for separate mounts, brackets & flags.
- Need for switch adjustments when shimming.
- Improper adjustment of outboard switches.
- Outboard switch vibrating loose in bracket.
- Protecting outboard proxies from being stepped on or bent in tools.

Pancake style Smart Stop
with wide or narrow blocks



Smart Stop shown in P5 slide

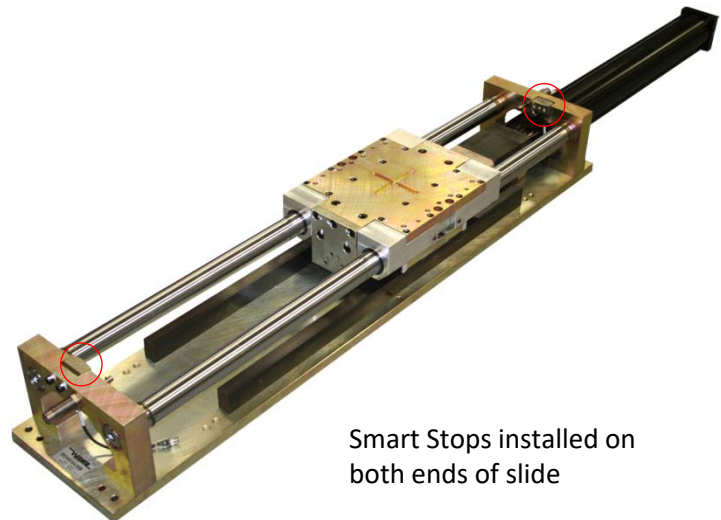
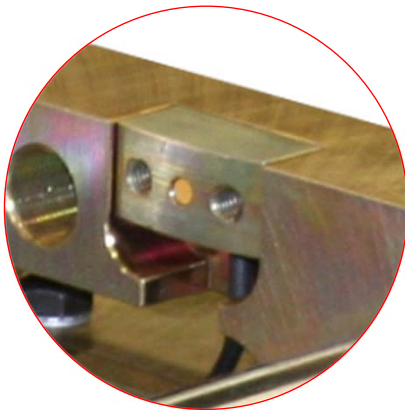

Smart Stops installed on
both ends of slide

Switches

Welker recommended standard stocking World Switch and Cylinder Switch
Check product catalogs for availability

Z World Switch

The Z switch is an inductive sensor with extremely bright triple luminous band indication. Ideal for use in harsh environments, such as direct- and alternating-field welding systems. An economical option available on many standard products. Order with sensors set to extend or retract position.

UB4 Shot Pin with
World Switch



L3 Cylinder Switch

The Welker L3 solid state cylinder-mounted sensor is immune to the majority* of direct and alternating field welding applications. Equal to World Switches in function and performance. Mounts easily to T-slot and tie rod cylinders. Weld spart resistant cable covers.



Expanding Pin with
L3 switch, mounted
to cylinder tie rods

*Note that some mid and low frequency DC resistance applications (i.e. aluminum resistance welding applications) may cause a fault. In these applications, it is recommended that the sensor be ignored/bypassed during the welding cycle.

Custom Products

Welker takes pride in our ability to access and focus on the application needs of our customers. We meet or exceed customer requirements with durable, low maintenance, cost effective solutions. Parts that perform multiple functions can help reduce the total number of parts and lower costs. Our engineering staff can design custom parts to operate in the most demanding applications using high performance materials, our proprietary bonding process and coatings that provide corrosion resistance and lower friction. In our well-equipped modern plant, our quality conscious machinists will manufacture your custom part to exact specification on time, every time.

Rinser slide for food processing conveyor



Multi-axis servo system for weld gun application

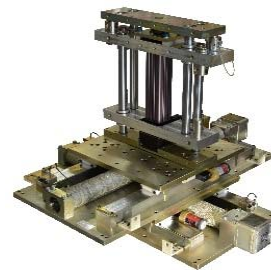

Super-size lockout pins for mining truck strut assembly



Custom bearings and bonding



Expanding Pin for engine block separation



Tooling Rotate Unit

