

## MAINTENANCE MANUAL UB SERIES SHOT PINS

### UB2

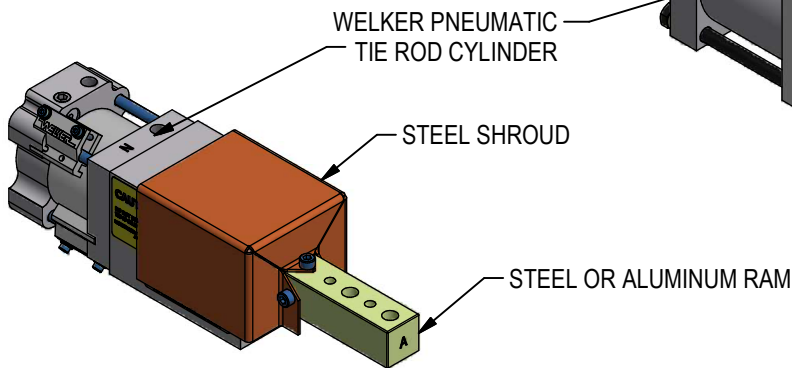

### UB4

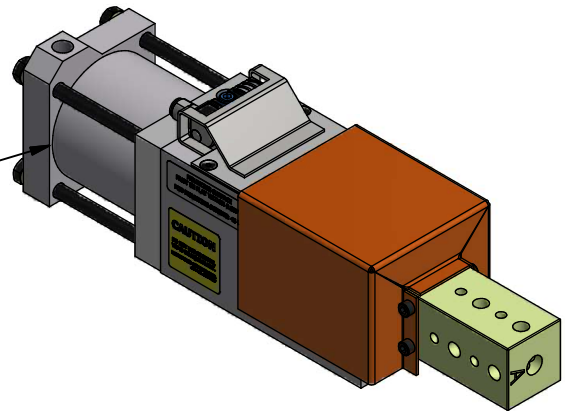

### UB2

WITH LEGACY PNEUMATIC CYLINDER:  
EXTRUSION STYLE TUBE

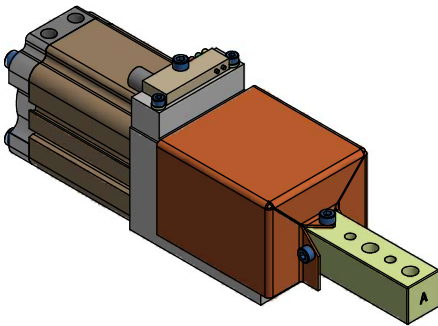

### S02345 ~ LONG STROKE UB4

FOR MAINTENANCE  
PROCEDURES, USE UB4  
INSTRUCTIONS

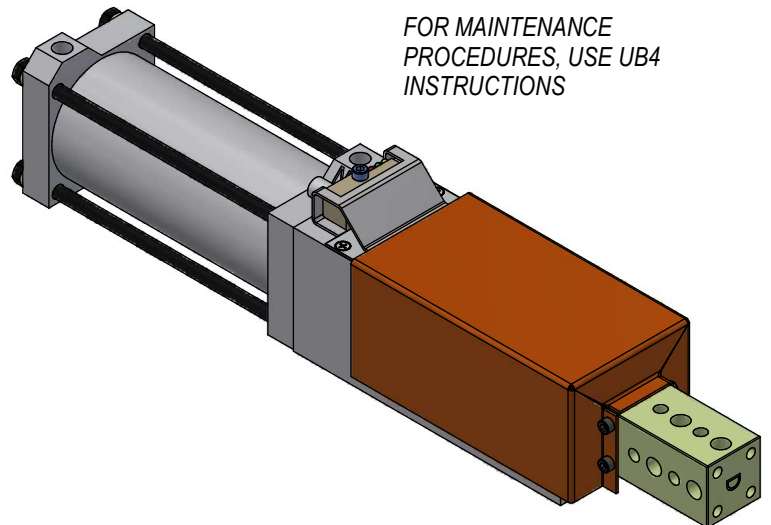

# **MAINTENANCE**

## ***SAFETY FIRST!***

MAINTENANCE SHOULD ONLY BE PERFORMED BY QUALIFIED PERSONNEL. PROPER SAFETY GEAR AND PROCEDURES MUST BE USED AT ALL TIMES.

BEFORE PERFORMING MAINTENANCE, CUT OFF AIR SUPPLY TO THE UNIT, ENSURE THAT ALL AIR IS REMOVED AND THAT THERE ARE NO "TRAPPED AIR" CONDITIONS.

PREVENTATIVE MAINTENANCE: Regularly inspect unit to verify proper operation. Check for debris build up and clean as needed. Inspect all pneumatic, electrical, and mounting connections, making sure all connections are tight and secure.

CYLINDER: Welker pneumatic cylinders are lube free and require very little maintenance. Check for abnormal wear or damage. Plant air supply to the cylinder should be free of contaminants, filtered to a minimum of 50micron and have a water separator. Be sure fittings are in good condition. Seals are subject to wear under normal operating conditions. It is recommended to keep a spare cylinder seal kit on hand.

SWITCH: Switches may fail and need replacement; it is recommended to keep a spare switch on hand.

WIPER: Welker recommends annual changing of urethane wiper. Wipers are maintenance items and are not covered under standard product warranty.

DETENT: Detent option's ball spring plunger is a wear item, not covered under standard warranty. Annual replacement is recommended.

OPERATION AFTER PROLONGED STORAGE: When installing a unit after prolonged storage (greater than 6 months) it is recommended to cycle the unit several dozen times prior to production use to allow the composite bearing system to ensure smooth operation.

WELKER RECOMMENDS IN-PLANT RE-CERTIFICATION AFTER SERVICE/REPAIR/REPLACEMENT.

# **TROUBLESHOOTING**

FAILURE	POSSIBLE CAUSE	SOLUTION
Unit does not extend/retract.	Cylinder failure Switch failure	Inspect unit for dirt/debris.  Check plant air supply for proper pressure; too little will result in lack of cylinder movement.  Seals may be worn, damaged or deteriorating. Replace as needed. If cylinder has been serviced, be sure tie rod nuts have been tightened to torque specifications.  Check switch for proper operation. Replace as needed.

# REPLACEMENT PARTS

QTY	STOCK*	DESCRIPTION	PART NUMBER
1	1	SWITCH	SEE CHART BELOW
1	1	UB2 WIPER	WIPER-24
1	1	UB4 & S02345 WIPER	WIPER-40-KIT
1	1	UB2 DETENT OPTION BALL PLUNGER	10016HP
1	1	UB4 DETENT OPTION BALL PLUNGER	10016HP
1	1	UB2 CYLINDER SEAL KIT	UB2N-CSK
1	1	UB4 CYLINDER SEAL KIT	UB4N-CSK
1	1	S02345 CYLINDER SEAL KIT	UB4N-CSK

\* RECOMMENDED SPARE PARTS TO KEEP IN STOCK

**EFFECTIVE 1/2/2023: World Switch ZE/ZR will be standard.**

All other world switches will be non-stock items that may affect price and delivery:

SWA, SWB, SWC, SWD, SWE, SWJ

	Reorder #	Mfr. Part Number	Manufacturer	Description
<b>World Switches</b>	<b>SWA</b>	Ni2-Q6.5-AP6-0.1-FS 4.4X3/S304	Turck	4-Wire, 4-Pin, DC M12 X 1 (PNP) Quick Disconnect
	<b>SWB</b>	Ni2-Q6.5-ADZ32-0.1-FSB 5.4X4/S304	Turck	4-Wire, 5-Pin, AC/DC 1/2-20 (N.O.) Quick Disconnect
	<b>SWC</b>	Ni2-Q6.5-AN6-0.1-FS 4.4X3/S304	Turck	4-Wire, 4-Pin, DC M12 X 1 (NPN) Quick Disconnect
	<b>SWD</b>	NBN2-F581-100S6-E8-V1	Pepperl & Fuchs	4-Wire, 4-Pin, DC M12 X 1 (PNP) Quick Disconnect
	<b>SWE</b> (UB4 ONLY)	BES-Z02KR2-PSC20F-P100-S04-V	Balluff	3-Wire, 4-Pin, DC M12 X 1 (PNP) Quick Disconnect
	<b>SWJ</b>	IN5374	Efector	3-Wire, 4-Pin, DC M12 X 1 (PNP) Quick Disconnect
	<b>SWZ</b>	WWS001A	Welker	4-Wire, 4-Pin, DC M12 X 1 (PNP) Quick Disconnect
	Reorder #	Mfr. Part Number	Manufacturer	Description
<b>Cylinder Switches</b>	<b>SWITCH L3</b>	SWITCH L3 L3 switch is weld field immune*, comparable to World Switches	Welker	4-Wire, 4-Pin, DC M12 X 1 (PNP) Quick Disconnect
	<b>SWITCH L5</b>	MK5113	ifm Efector	3-Wire, 4-Pin, DC M12 X 1 (NPN) Quick Disconnect

**Standard Switch Option - All other options may affect price and delivery**

\*Note that some mid and low frequency DC resistance applications (i.e. aluminum resistance welding applications) may cause a fault. In these applications, it is recommended that the sensor be ignored/bypassed during the welding cycle.

# WORLD SWITCH INSTALLATION: UB4

1. REMOVE SHROUD (4 SCREWS).
2. REMOVE UNIT COVER PLATE (4 SCREWS).
3. FULLY EXTEND RAM.
4. LOCATE M6 X 16 SHOULDER SCREW IN RAM. CALL WELKER IF SHOULDER SCREW IS MISSING.
5. INSTALL PINS IN SWITCH SENSORS, 2 PER SENSOR.
6. INSTALL SWITCH INTO SHOT PIN BODY USING SWITCH FASTENER.
7. INSTALL SWITCH SENSORS IN UNIT BODY: FOR RETRACT OPTION INSTALL SENSOR S01 IN FIXED SLOT; INSTALL S02 IN OBLONG SLOT. FOR EXTEND OPTION INSTALL SENSOR S02 IN FIXED SLOT; INSTALL S01 IN OBLONG SLOT.
8. INSTALL SECOND SENSOR IN OBLONG SLOT, ALIGNING CENTER MARK TO CENTER OF SHOULDER BOLT IN RAM. FOR LONG STROKE UNITS, SECOND SENSOR MAY NEED TO BE INSTALLED UPSIDE DOWN. INSTALL PINS IN OPPOSITE SIDE OF SENSOR. SECURE WIRE IN OBLONG SLOT WITH EXTRA PIN SO IT DOESN'T INTERFERE WITH UNIT OPERATION.
9. INSTALL COVER PLATE AND SHROUD.

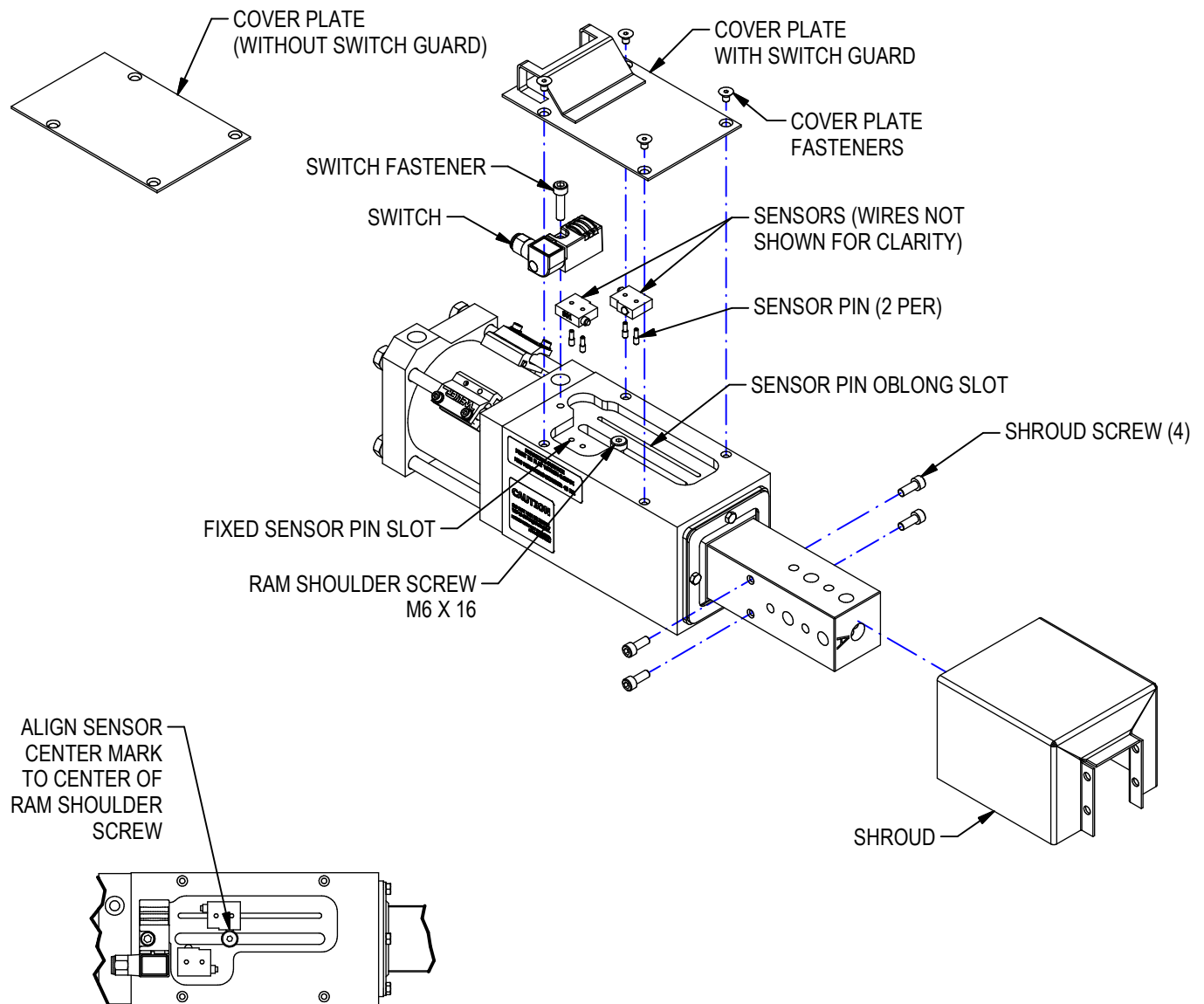

# WORLD SWITCH INSTALLATION: UB2

1. REMOVE SHROUD (3 SCREWS).
2. REMOVE UNIT COVER PLATE (4 SCREWS).
3. REMOVE SWITCH FASTENER AND SWITCH GUARD. REMOVE OLD SWITCH AND SENSORS NOTING SENSOR S01 AND S02 (OR S1 AND S2) POSITION IN UNIT BODY.
4. INSTALL PINS IN SWITCH SENSORS, 2 PER SENSOR.
5. INSTALL SENSOR SPACERS TO SENSOR PINS. POSITION SENSORS IN UNIT BODY, SAME LOCATIONS AS OLD SWITCH.
6. INSTALL SWITCH AND SWITCH GUARD TO SHOT PIN BODY WITH FASTENERS.
7. INSTALL COVER PLATE AND SHROUD.

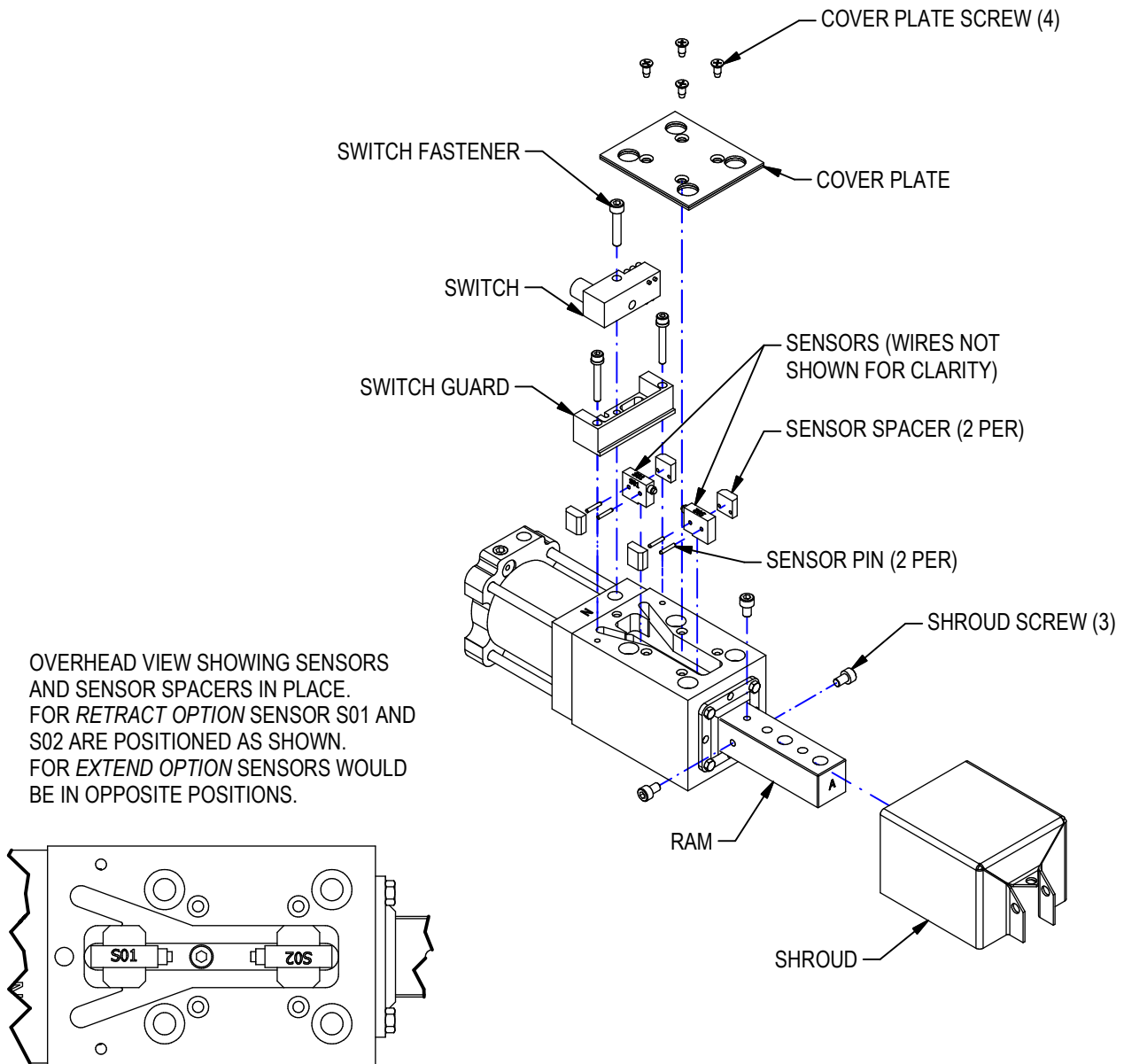

## WIPER MAINTENANCE

Welker recommends annual changing of urethane wiper. Wipers are maintenance items and are not covered under standard product warranty. Steam cleaning or wiping contamination off during the course of normal machine maintenance is desirable.

1. Disengage plant air from unit. Remove tooling from unit ram.
2. Remove shroud screws. Remove shroud.
3. Remove wiper screws. Remove wiper retainer (UB4 only). Remove wiper.
4. Clean ram, removing residual debris.
5. Install new wiper using a small amount of Magnalube G grease.
6. Replace wiper retainer (UB4 only).
7. Install wiper screws.
8. Install shroud with shroud screws.
7. Install tooling on unit ram.
8. Engage plant air, making sure lines are free of contaminants.

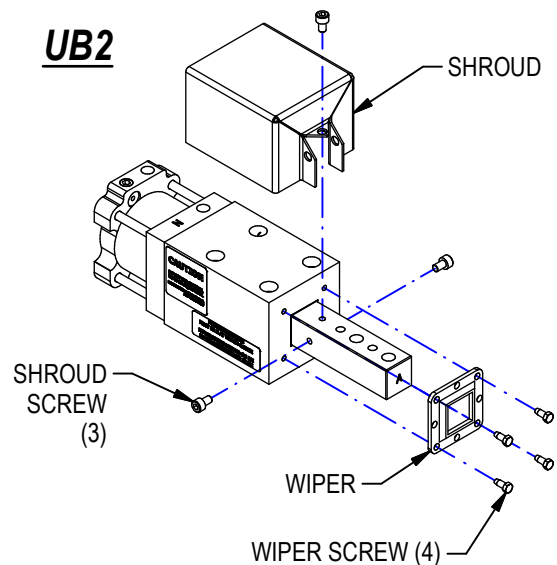
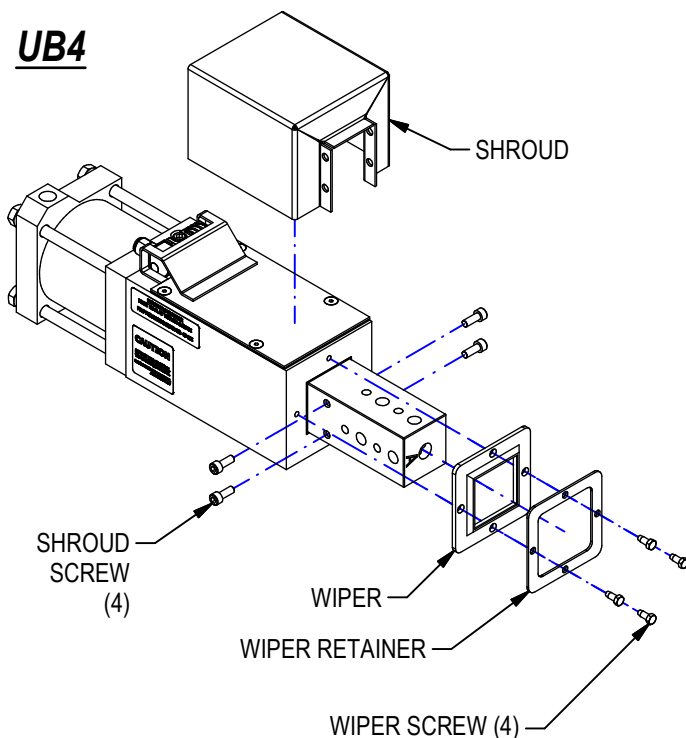

# DETENT OPTION MAINTENANCE

Detent option's ball spring plunger is a maintenance item, not covered under standard product warranty.

1. Disengage plant air from unit. Remove tooling from unit ram.
2. Remove shroud screws. Remove shroud.
3. Note location of plunger. Unit body features holes on both sides for detent option. Plunger is installed according to rap/rigid coupler option. Units with rigid coupler option, plunger will be located as shown below. Units with rap coupler option, plunger will be on opposite side. A set screw is installed in non-plunger hole.
4. Remove plunger noting depth in unit body.
5. Clean any debris from unit.
6. Install new plunger to same depth as old. Plunger includes thread locking element. Do not install plunger deeper than original plunger.
7. Install shroud with shroud screws.
8. Engage plant air, making sure lines are free of contaminants.

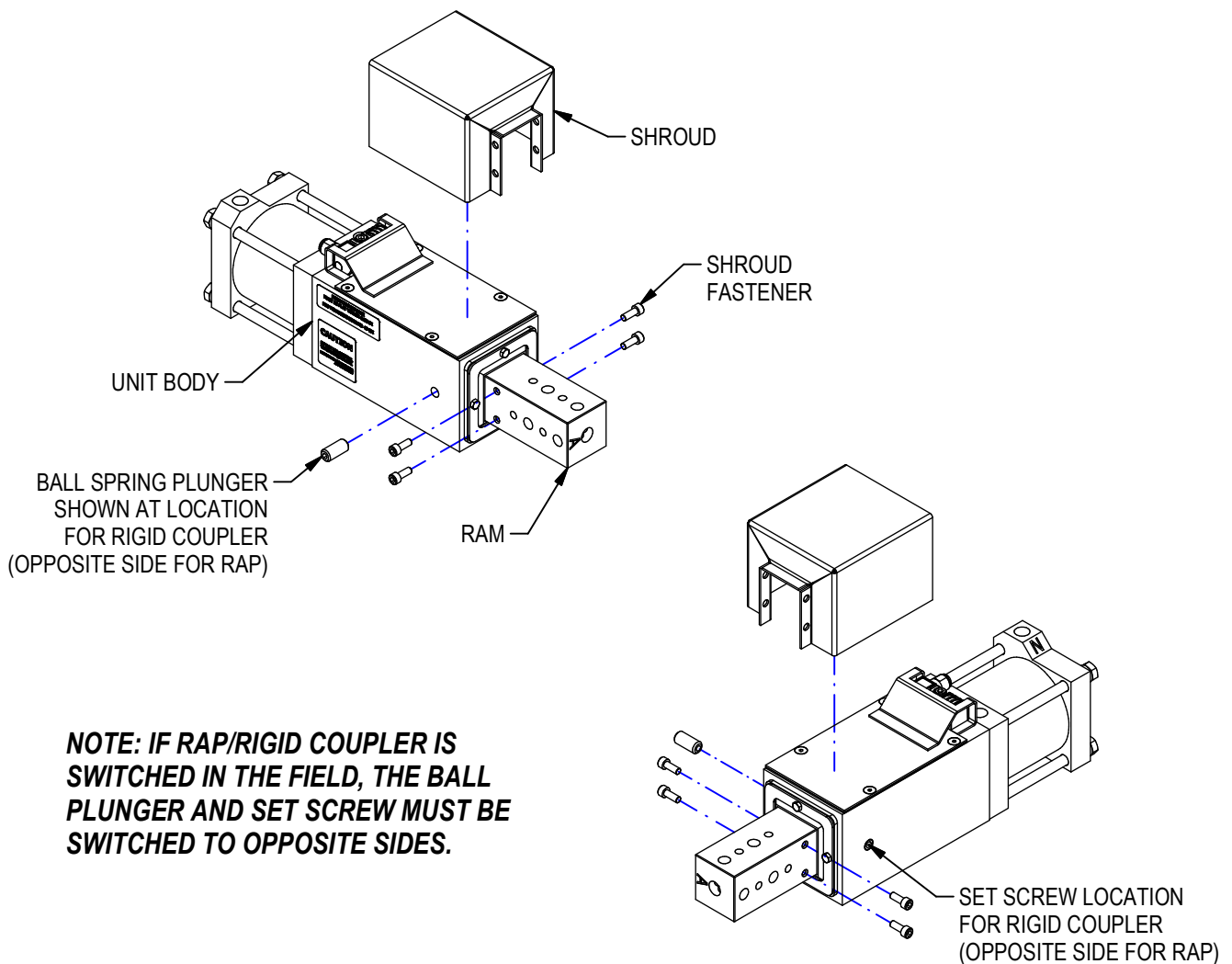

**NOTE: IF RAP/RIGID COUPLER IS SWITCHED IN THE FIELD, THE BALL PLUNGER AND SET SCREW MUST BE SWITCHED TO OPPOSITE SIDES.**

# UB4 SERIES SHOT PIN ~ CSK MAINTENANCE

UB4N-CSK includes tube bumper seals (2), o-ring tube seal, square ram seal, rod wiper, piston seal and adapter inner & outer seals.

1. When replacing seals: Note seal orientation when removing. Clean seal grooves thoroughly. Lightly coat new seals and tube I.D. with Magnalube G or equivalent.
2. Disengage plant air from unit. Disconnect and remove cylinder switch if present, noting positions on tie rods.
3. Remove tie bolts & lock washers from rear end cap. Remove end cap noting port orientation.
4. Remove cylinder tube & tube seal.
5. Remove rigid adapter, noting location (see detail below). Not applicable in all units.
6. Remove piston from ram coupler. Remove piston seal using plastic or brass tool. Clean seal groove. Replace piston seal.
7. Remove front end cap noting port orientation. Replace tube seals on end caps.
8. Replace square ram seal.
9. Install front end cap. Install piston to ram coupler.
10. Install the rigid adapter to same location.
11. Align center of piston to center of ram when installing cylinder tube.
12. Install rear end cap. Be sure tube seals are properly seated. Secure with tie rods/lock washers. Tighten in an "X" pattern to torque specifications.
13. Engage plant air, making sure lines are free of contaminants. Reconnect switch. Test.

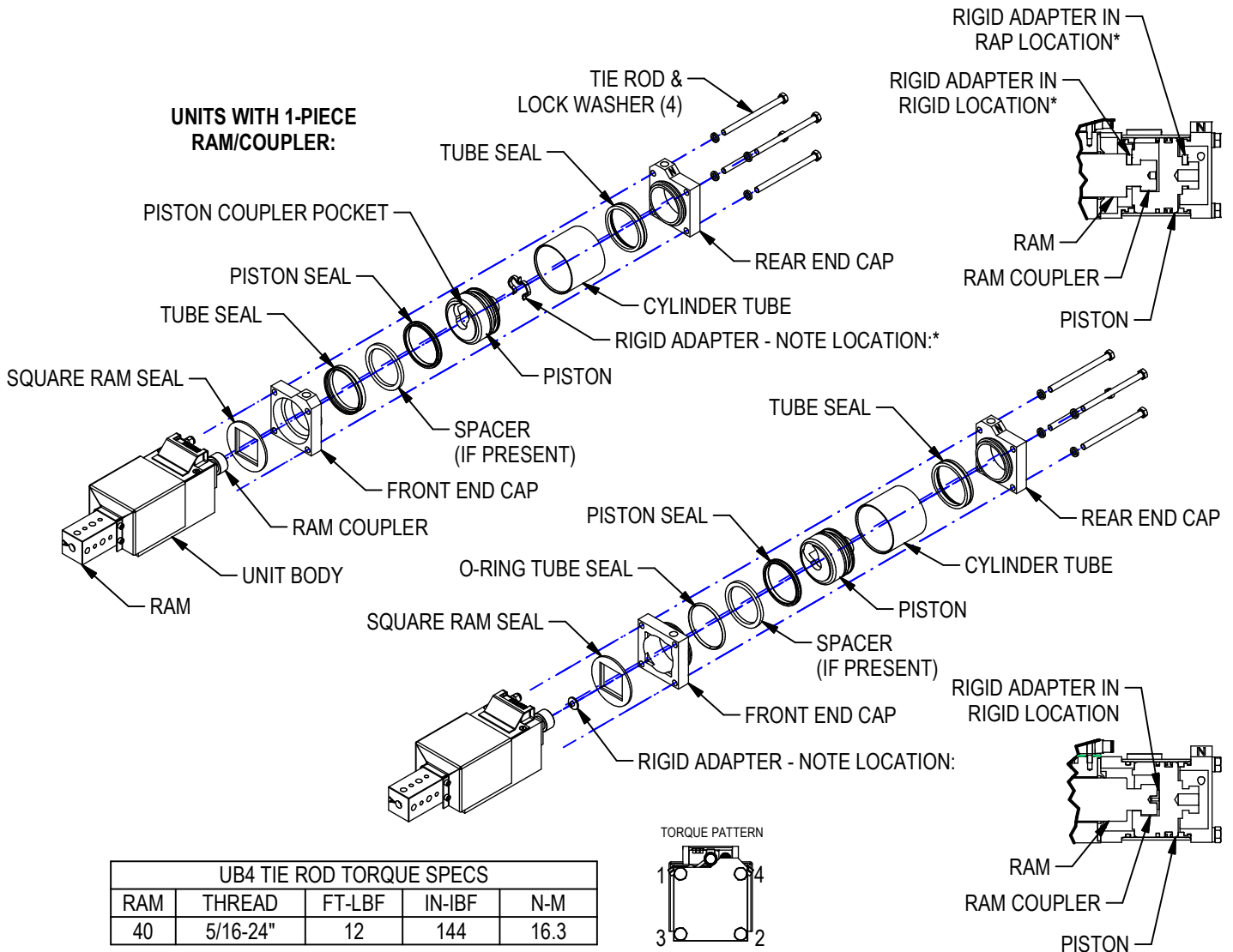

UB4 TIE ROD TORQUE SPECS				
RAM	THREAD	FT-LBF	IN-IBF	N-M
40	5/16-24"	12	144	16.3

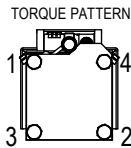



# UB4 SERIES SHOT PIN UNITS W/COUPLER ~ CYLINDER MAINTENANCE

UB4N-CSK includes tube seals (2), o-ring tube seal, square ram seal, rod wiper, piston seal and adapter inner & outer seals.

1. When replacing seals: Note seal orientation when removing. Clean seal grooves thoroughly. Lightly coat new seals and tube I.D. with Magnalube G or equivalent.
2. Disengage plant air from unit. Disconnect and remove cylinder switch if present, noting positions on tie rods.
3. Remove tie bolts & lock washers from rear end cap. Remove end cap noting port orientation. Remove cylinder tube & tube seal.
4. If unit is rap coupler, remove rigid adapter from piston plug.
5. Piston plug is installed with removable adhesive. Use belt or strap wrench to loosen piston plug being careful not to scratch or damage piston. Remove piston plug and plug seal.
6. Remove coupler and piston. If unit is rigid coupler, the rigid adapter will be located between piston and ram.
7. Remove piston seal using plastic or brass tool. Clean seal groove. Replace piston seal.
8. Remove front end cap noting port orientation. Replace tube seals on end caps.
9. Replace square ram seal.
10. Install front end cap.
11. Install piston to ram with coupler, using permanent adhesive on threads.
12. Insert plug seal into piston. Install piston plug to piston using removable adhesive on threads.
13. Install the rigid adapter to same location.
14. Install cylinder tube and rear end cap. Be sure tube seals are properly seated. Secure with tie rods/lock washers. Tighten in an "X" pattern to torque specifications.
15. Engage plant air, making sure lines are free of contaminants. Reconnect switch. Test.

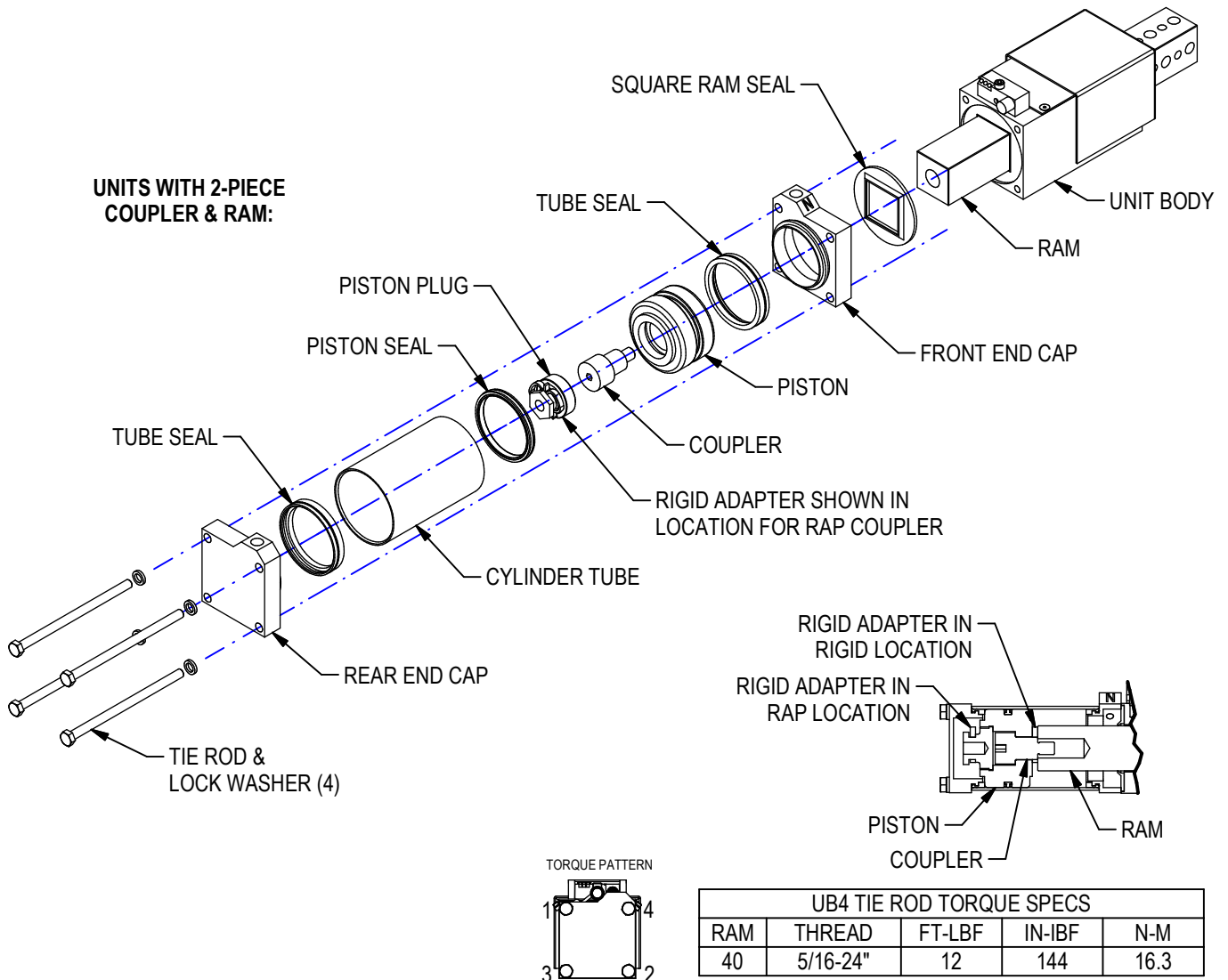

# UB4 SERIES SHOT PIN ~ CSK MAINTENANCE

FOR UNITS WITH DOUBLE ROD CYLINDER (ACTUATOR 03/04)

1. When replacing seals: Note seal orientation when removing. Clean seal grooves thoroughly. Lightly coat new seals and tube I.D. with Magnalube G or equivalent.
2. Disengage plant air from unit. Disconnect and remove cylinder switch if present, noting positions on tie rods.
3. Remove fixed/adjustable stop.
4. Remove tie bolts & lock washers from stop plate. Remove stop plate.
5. Remove adapter. Replace inner and outer adapter seals. Replace rod wiper.
6. Remove end cap noting port orientation.
7. Remove cylinder tube.
8. Remove rigid adapter located between piston and ram. Not applicable in all units.
9. Cylinder stop rod is installed with removable adhesive. Use belt or strap wrench to loosen piston plug being careful not to scratch piston.
10. Remove piston seal using plastic or brass tool. Clean seal groove. Replace piston seal.
11. Remove second end cap. Replace tube seals on end caps.
12. Replace square ram seal.
13. Install end cap.
14. Install piston to ram with coupler, using permanent adhesive on threads.
15. Install the rigid adapter to same location.
16. Install cylinder tube, end cap, and adapter. Be sure tube seals are properly seated.
17. Install rod stop plate. Secure with tie rods/lock washers. Tighten in an "X" pattern to torque specifications.
18. Install fixed/adjustable stop.
19. Engage plant air, making sure lines are free of contaminants. Reconnect switch. Test.

**NOTE: COUPLERLESS PISTON UNIT SHOWN.  
SEE SHEET 9 FOR UB4 WITH  
COUPLER/PISTON ASSEMBLY DETAILS**

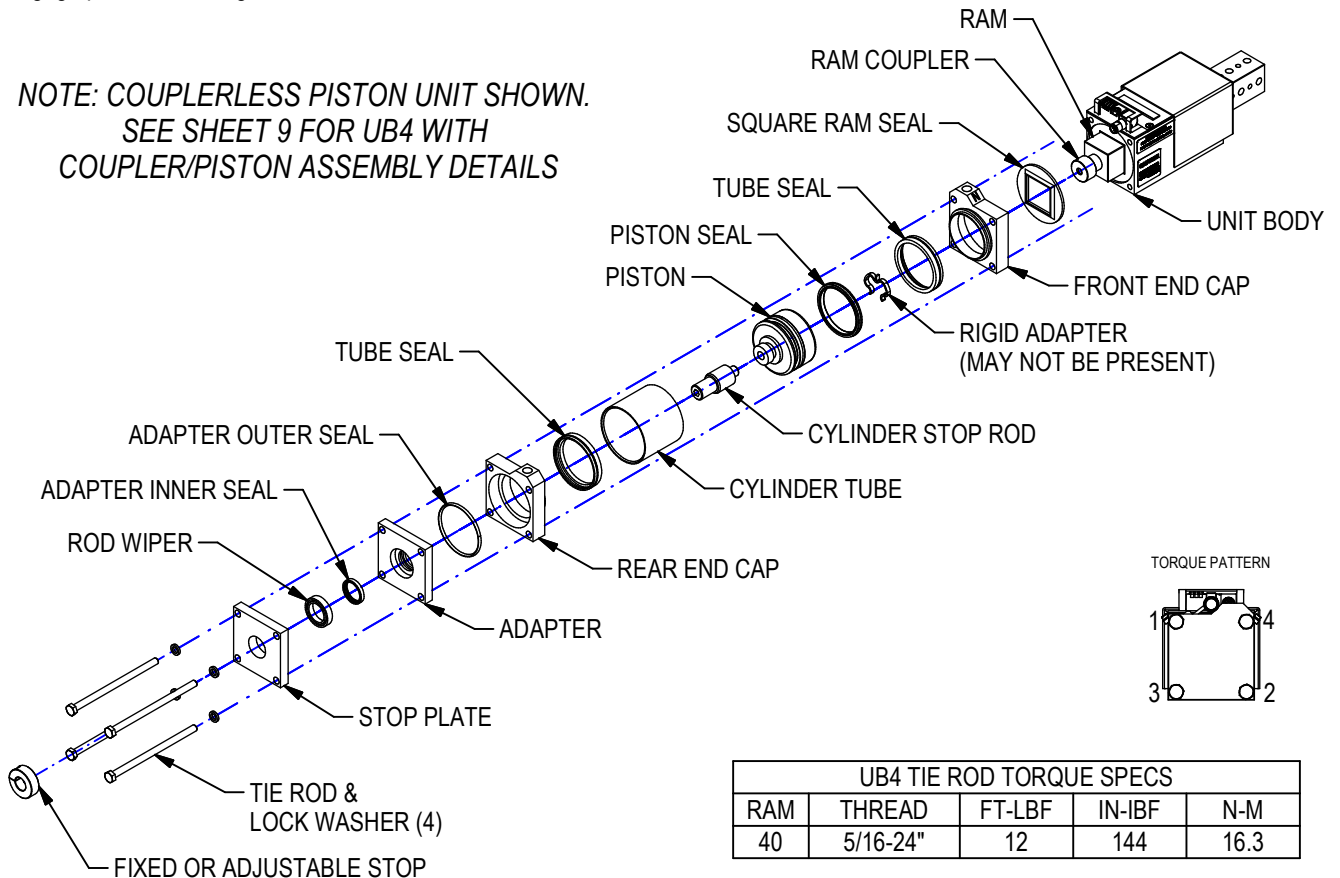

UB4 TIE ROD TORQUE SPECS				
RAM	THREAD	FT-LBF	IN-IBF	N-M
40	5/16-24"	12	144	16.3

# UB2 SERIES SHOT PIN ~ CSK MAINTENANCE

UB2N-CSK includes end cap seal, square ram seal, rod wiper, piston seal and internal port seals.

1. When replacing seals: Note seal orientation when removing. Clean seal grooves thoroughly. Lightly coat new seals and tube I.D. with Magnalube G or equivalent.
2. Disengage plant air from unit. Disconnect and remove cylinder switch if present, noting positions on tie rods.
3. Remove screws & lock washers from end cap. Remove end cap and cylinder tube noting orientation. Remove internal port seal (legacy cylinder only). Clean seal grooves thoroughly. Replace end cap seal.
4. Remove rigid adapter, noting location.
5. FOR UNITS WITH 2-PIECE COUPLER & RAM: Piston plug is installed with removable adhesive. Use belt or strap wrench to loosen piston plug being careful not to scratch or damage piston. Remove piston plug. Remove coupler and piston.
6. FOR UNITS WITH 1-PIECE COUPLER/RAM: Remove piston from coupler by sliding out of coupler pocket.
7. Remove piston seal using plastic or brass tool. Clean seal groove. Replace piston seal.
8. Remove spacer if present.
9. Replace square ram seal. Install spacer if present.
10. FOR UNITS WITH 2-PIECE COUPLER & RAM: Install piston to ram with coupler, using removable adhesive on threads. Install piston plug to piston using removable adhesive on threads.
11. FOR UNITS WITH 1-PIECE COUPLER/RAM: Install piston to ram at coupler pocket.
12. Install the rigid adapter to same location.
13. Install new internal port seal (legacy cylinder only).
14. Install cylinder tube and end cap. Secure with tie screws/lock washers. Tighten in an "X" pattern to torque specifications.
15. Engage plant air, making sure lines are free of contaminants. Reconnect switch. Test.

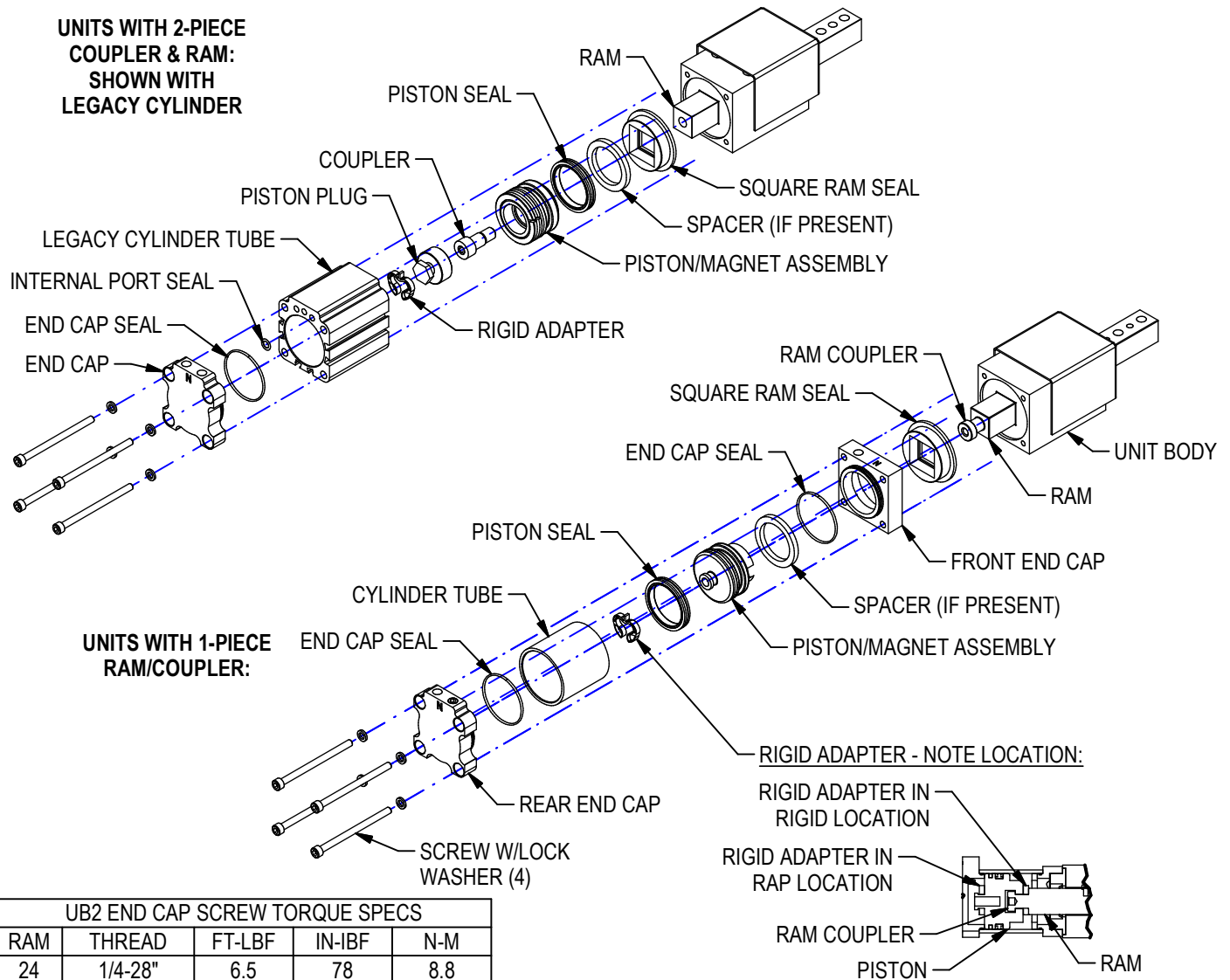

UB2 END CAP SCREW TORQUE SPECS				
RAM	THREAD	FT-LBF	IN-IBF	N-M
24	1/4-28"	6.5	78	8.8

# UB2 SERIES SHOT PIN ~ CSK MAINTENANCE

FOR UNITS WITH DOUBLE ROD CYLINDER (ACTUATOR 03/04) COUPLERLESS UNIT SHOWN

1. When replacing seals: Note seal orientation when removing. Clean seal grooves thoroughly. Lightly coat new seals and tube I.D. with Magnalube G or equivalent.
2. Disengage plant air from unit. Disconnect and remove cylinder switch if present, noting positions on tie rods.
3. Remove fixed/adjustable stop.
4. Remove screws & lock washers from stop plate. Remove stop plate.
5. Remove cylinder stop rod. Replace rod wiper
6. Remove end cap, noting port orientation. Replace end cap seal.
7. Remove cylinder tube.
8. FOR UNITS WITH 2-PIECE COUPLER & RAM: Piston plug is installed with removable adhesive. Use belt or strap wrench to loosen piston plug being careful not to scratch or damage piston. Remove piston plug. Remove coupler and piston.
9. FOR UNITS WITH 1-PIECE COUPLER/RAM: Remove piston from coupler by sliding out of coupler pocket.
10. Remove rigid adapter located between piston and ram.
11. Remove piston seal using plastic or brass tool. Clean seal groove. Replace piston seal.
12. Remove second end cap. Replace tube seals on end caps.
13. Replace square ram seal.
14. FOR UNITS WITH 2-PIECE COUPLER & RAM: Install piston to ram with coupler, using removable adhesive on threads. Install piston plug to piston using removable adhesive on threads.
15. FOR UNITS WITH 1-PIECE COUPLER/RAM: Install piston to ram at coupler pocket.
16. Install the rigid adapter to same location.
17. Install cylinder tube, end cap, and adapter. Secure with cylinder stop rod.
18. Install rod stop plate. Secure with tie rods/lock washers. Tighten in an "X" pattern to torque specifications. Install fixed/adjustable stop.
19. Engage plant air, making sure lines are free of contaminants. Reconnect switch. Test.

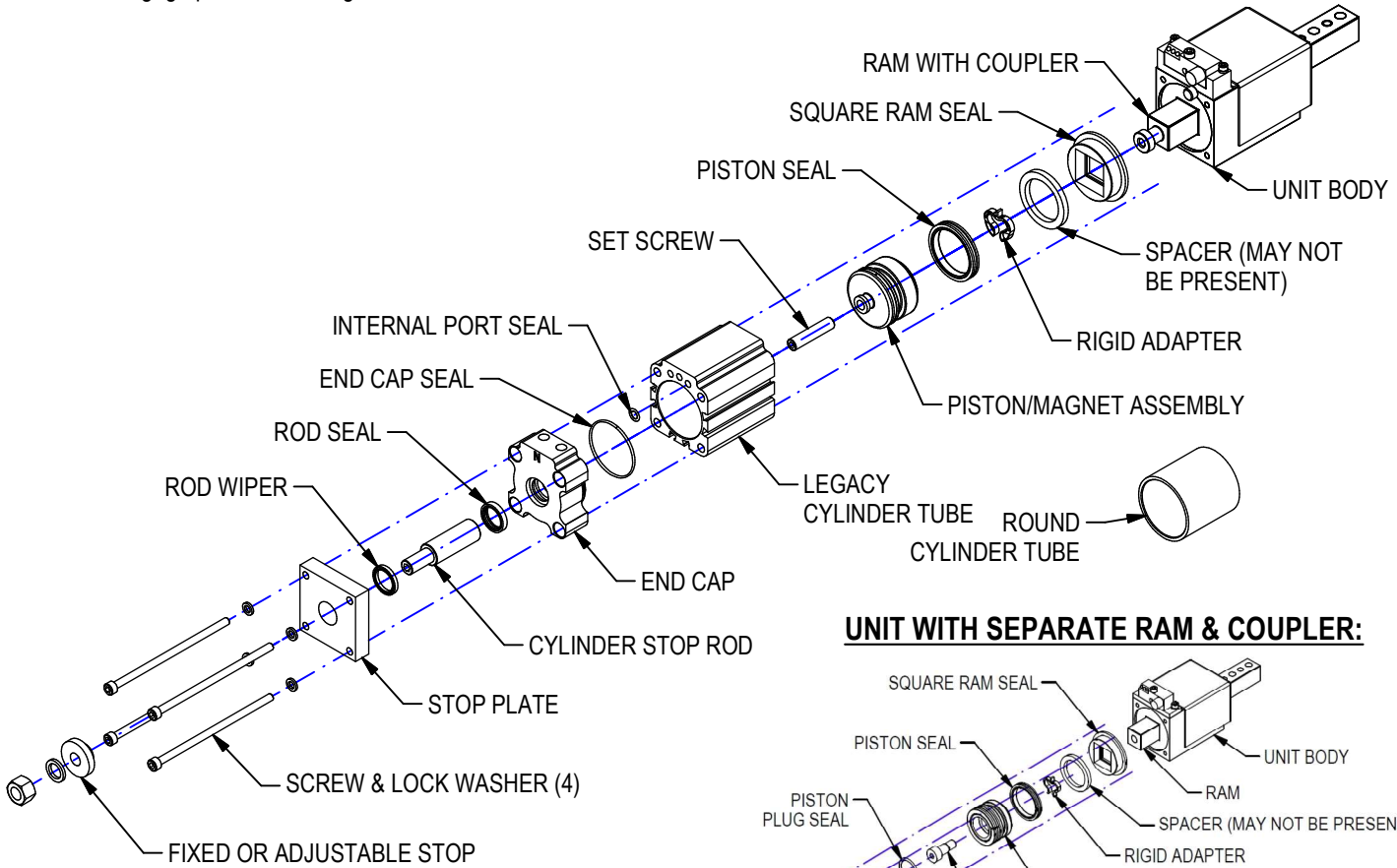

UB2 END CAP SCREW TORQUE SPECS				
RAM	THREAD	FT-LBF	IN-IBF	N-M
24	1/4-28"	6.5	78	8.8